

Forward Modeling of CME Events Using STEREO-SECCHI

A. Thernisien, R.A. Howard, A. Vourlidas
NRL

SWG, Meudon, April 2008

Introduction

- **Goal:** determine the unprojected CME position, direction and speed using SECCHI observations.
 - **Method:** forward modeling.
 - Use an ad hoc geometric flux rope model.
 - Use data where separation is $> 40^\circ$ (after Nov. 2007)
 - Fit manually the model to both A and B views.
-
-

A Geometric Flux Rope Model

The Hollow Croissant Model

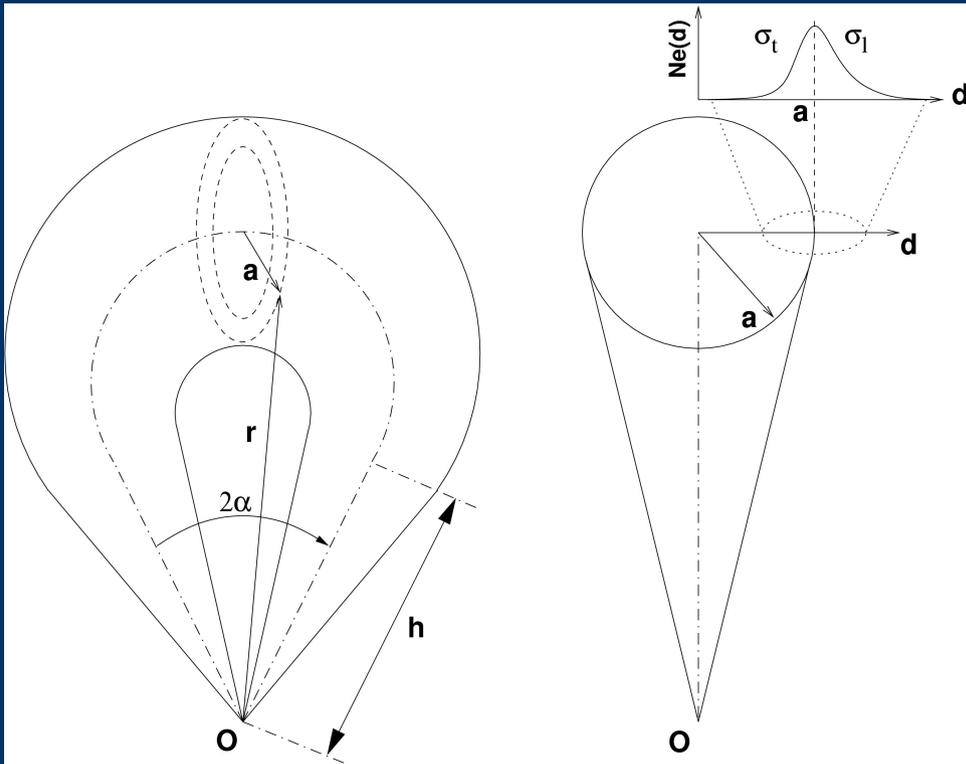

A Geometric Flux Rope Model

The Hollow Croissant Model

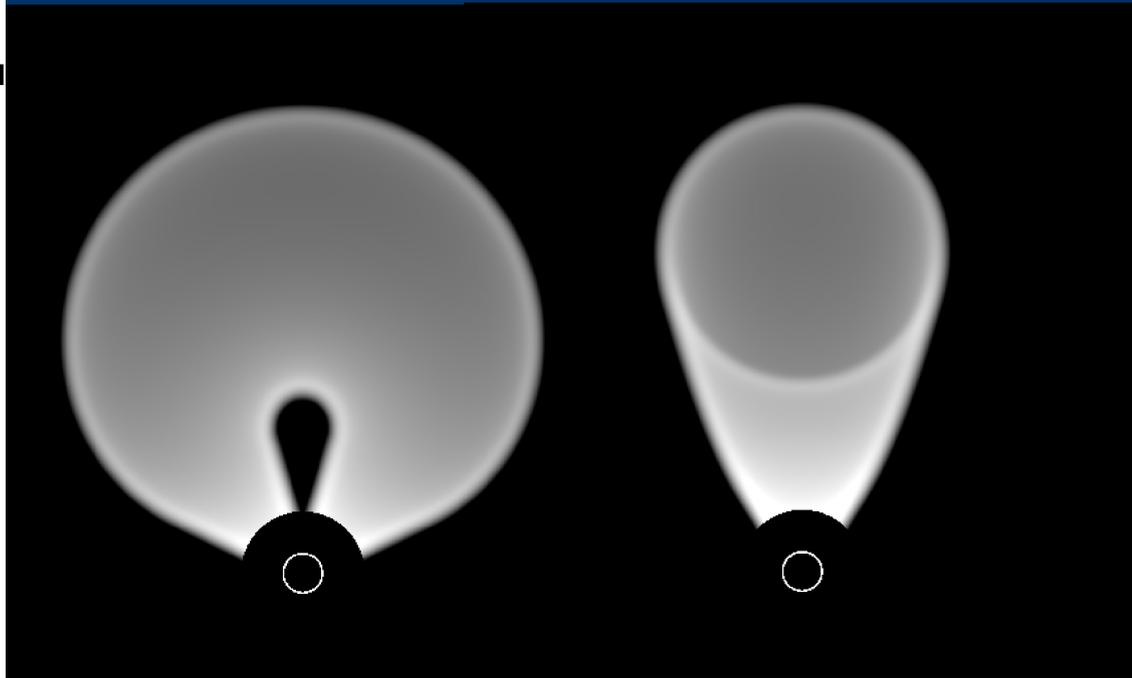
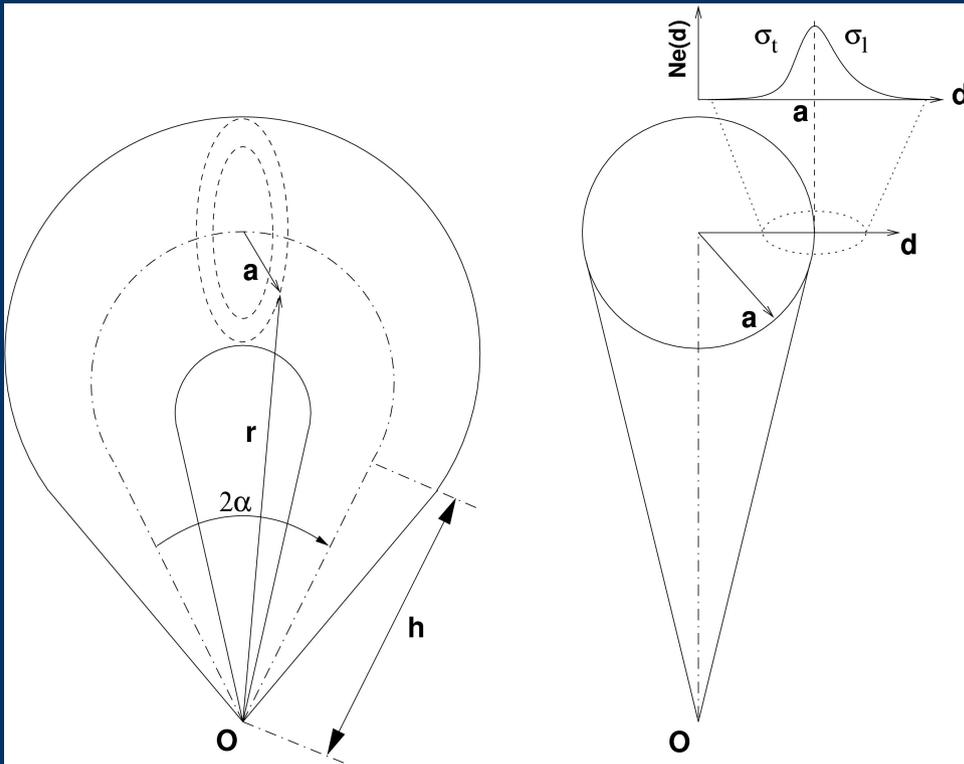

A Geometric Flux Rope Model

The Hollow Croissant Model

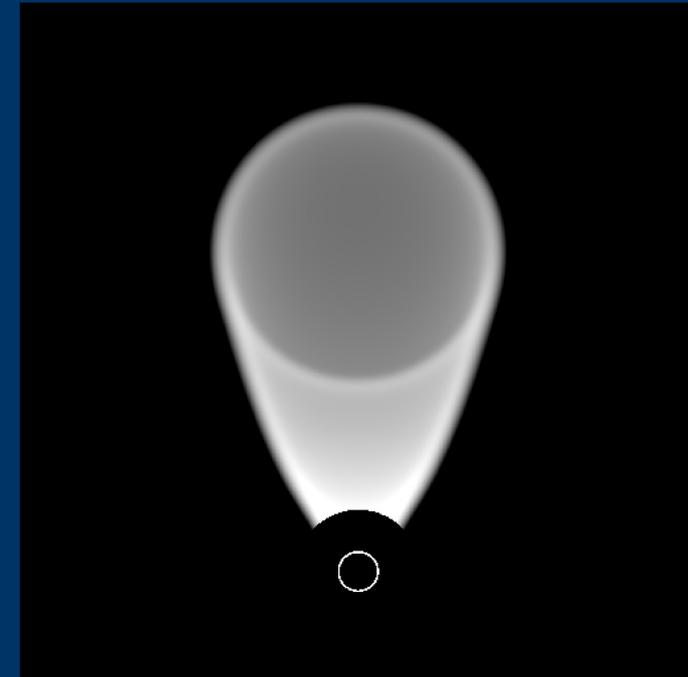
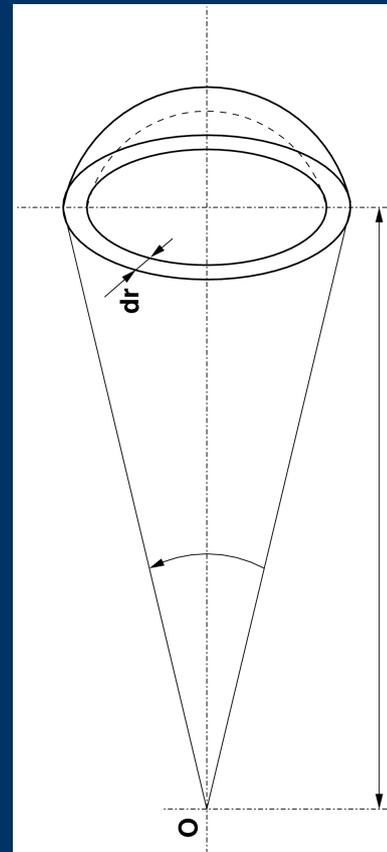
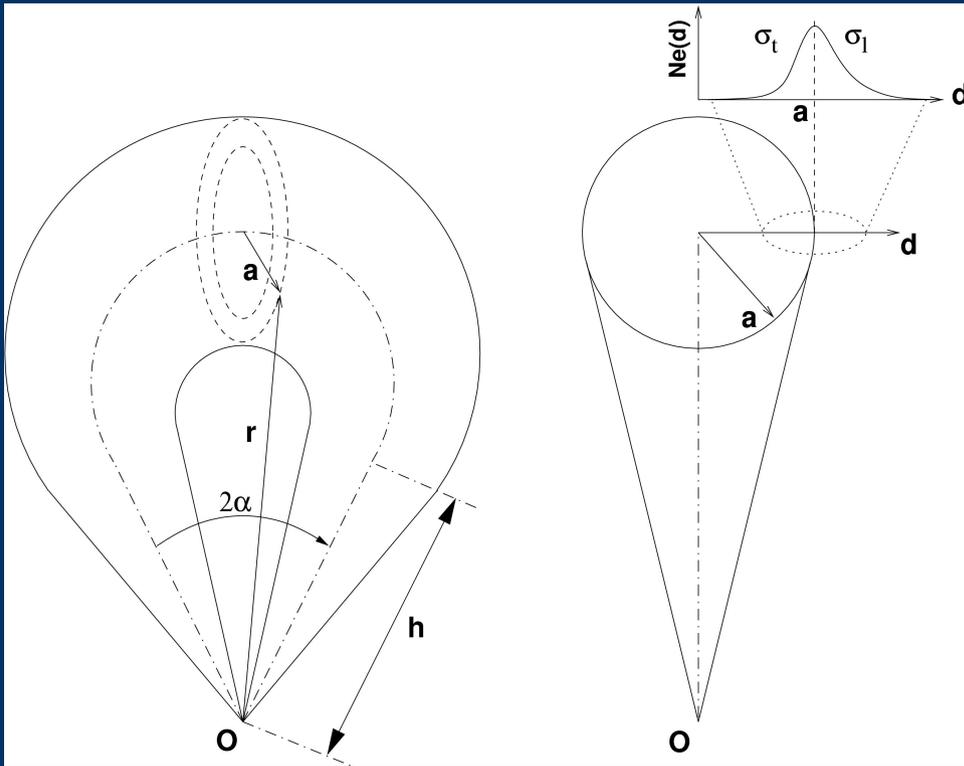

If $\alpha = 0 \Rightarrow$ it is equivalent to an ice cream cone model

Positioning the Model

Front or back ?

View from the pole

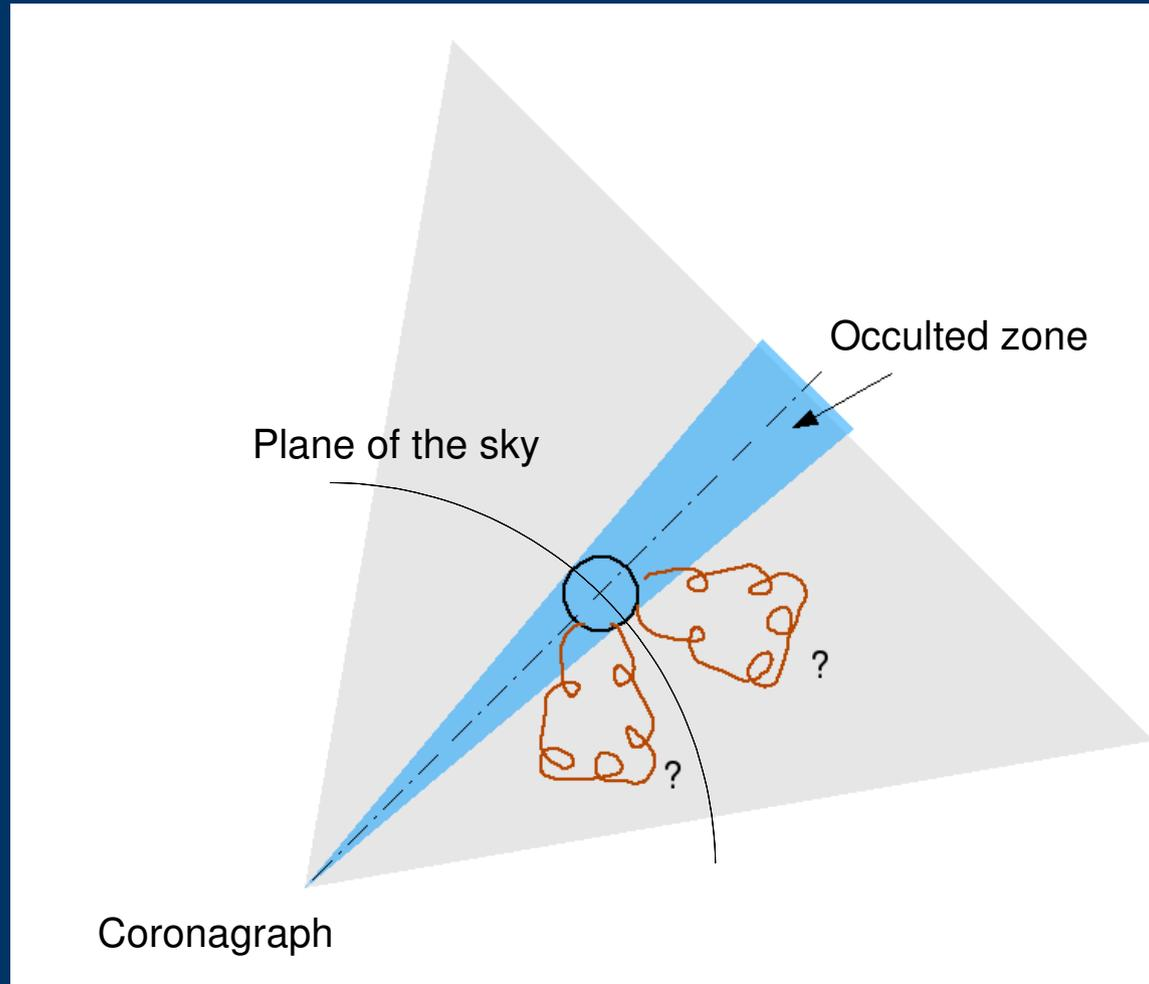

Positioning the Model

Using one view

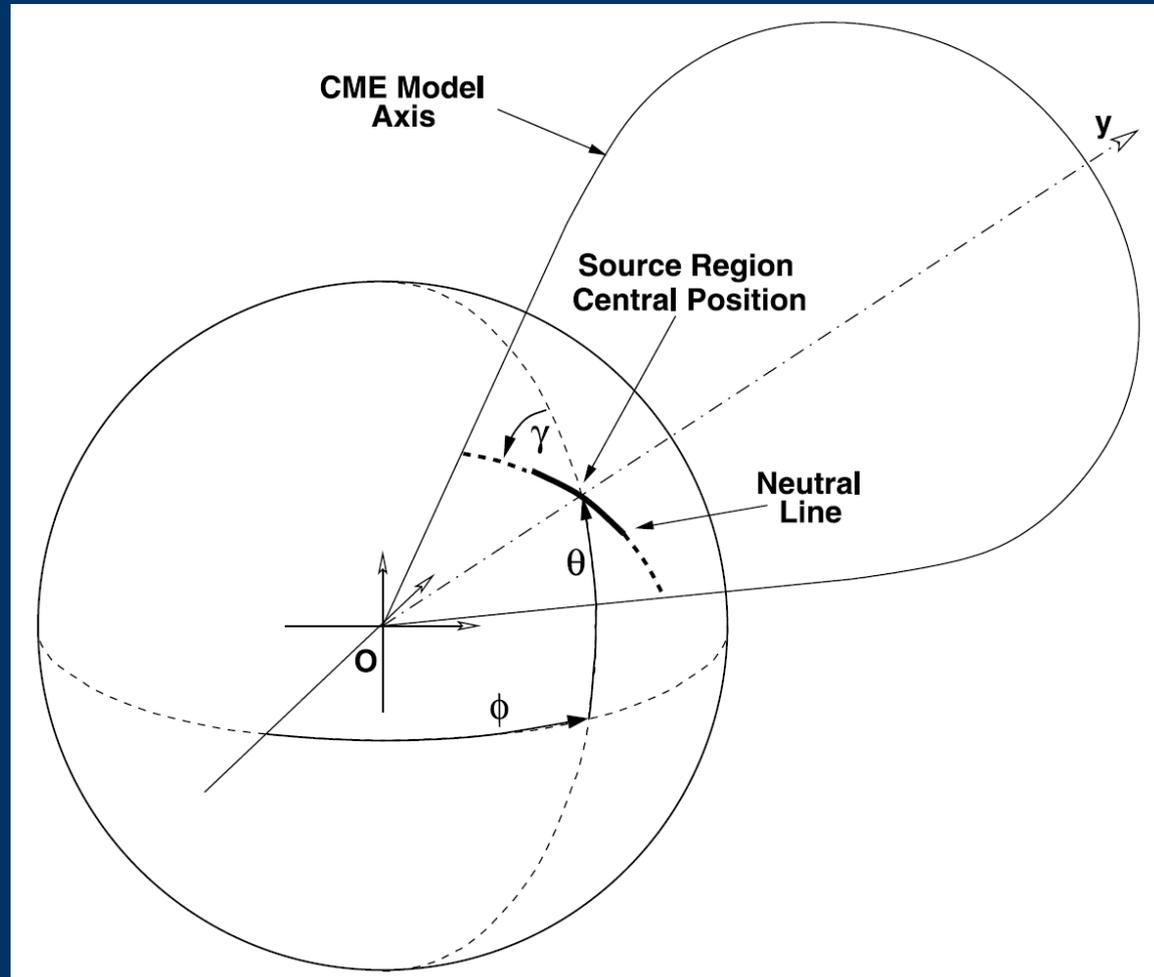

Use position the SR detected by EIT: it has to be visible !

Modeling of Flux-Rope CMEs

Application to LASCO C2 Events

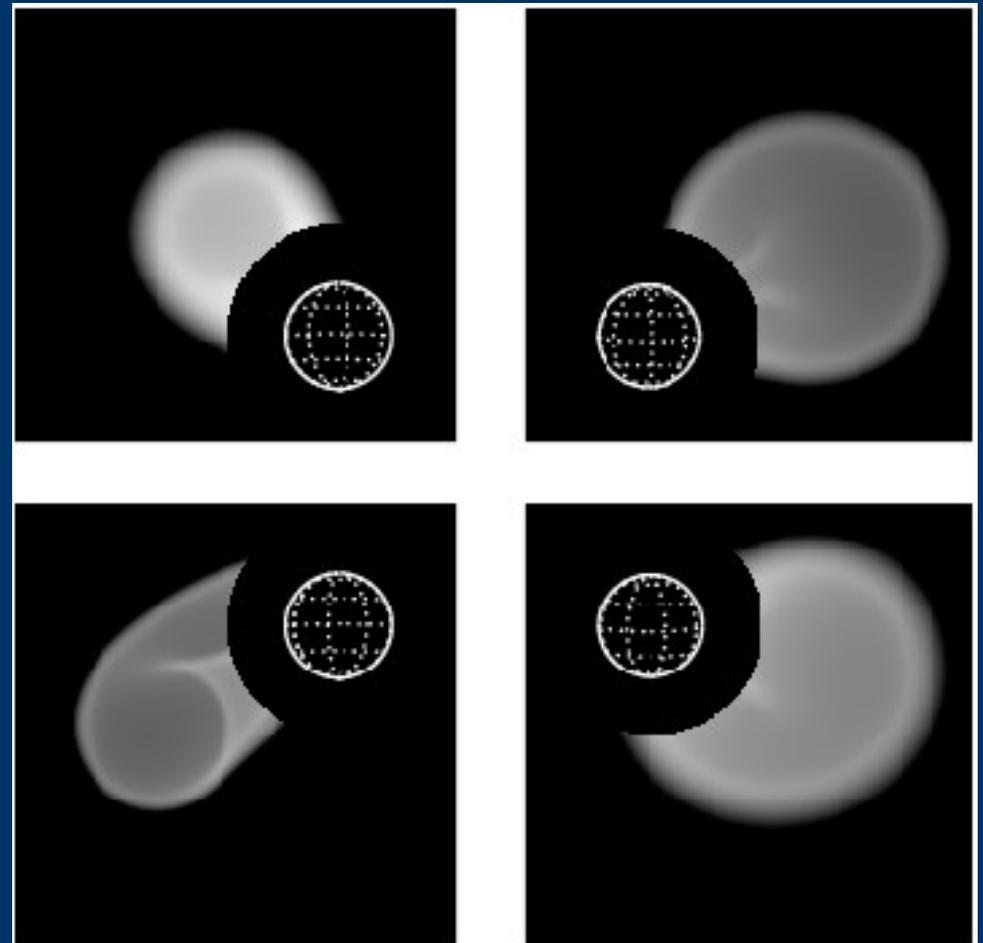
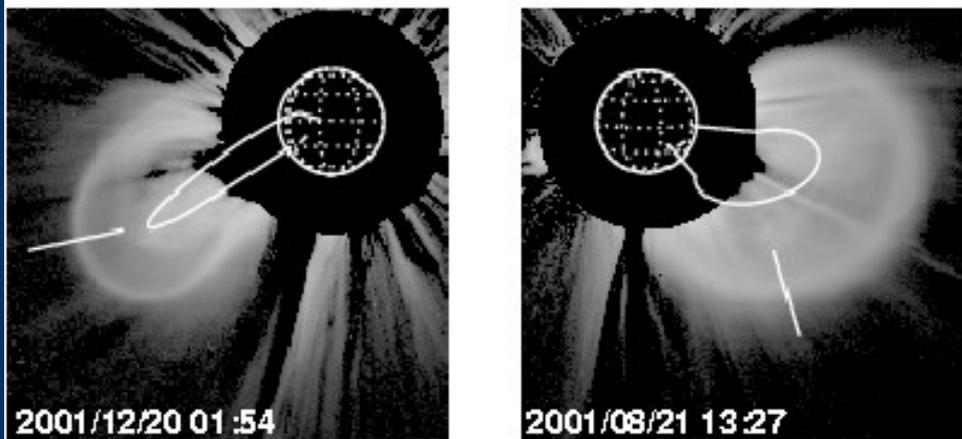
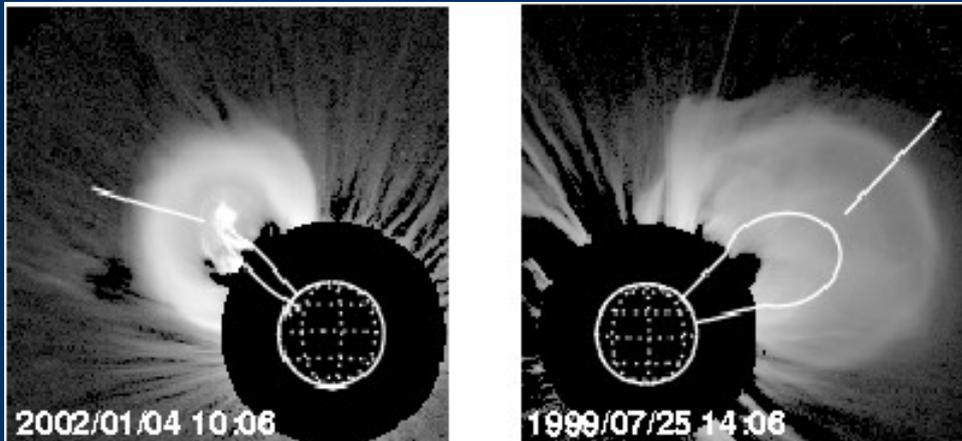

Cremades & Bothmer, 2004, Thernisien, Howard & Vourlidas, 2006

Observing a CME with STEREO-SECCHI

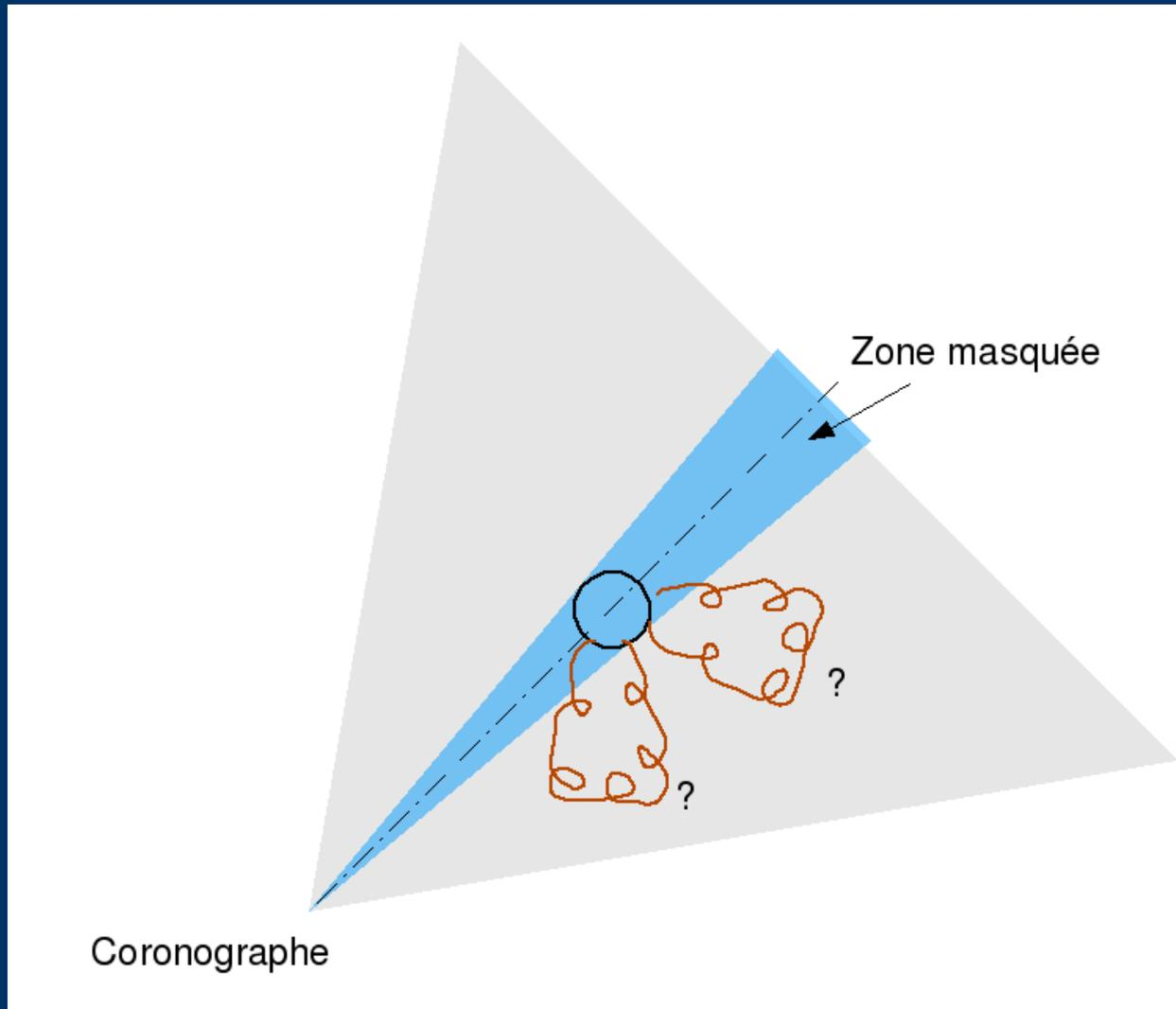

Observing a CME with STEREO-SECCHI

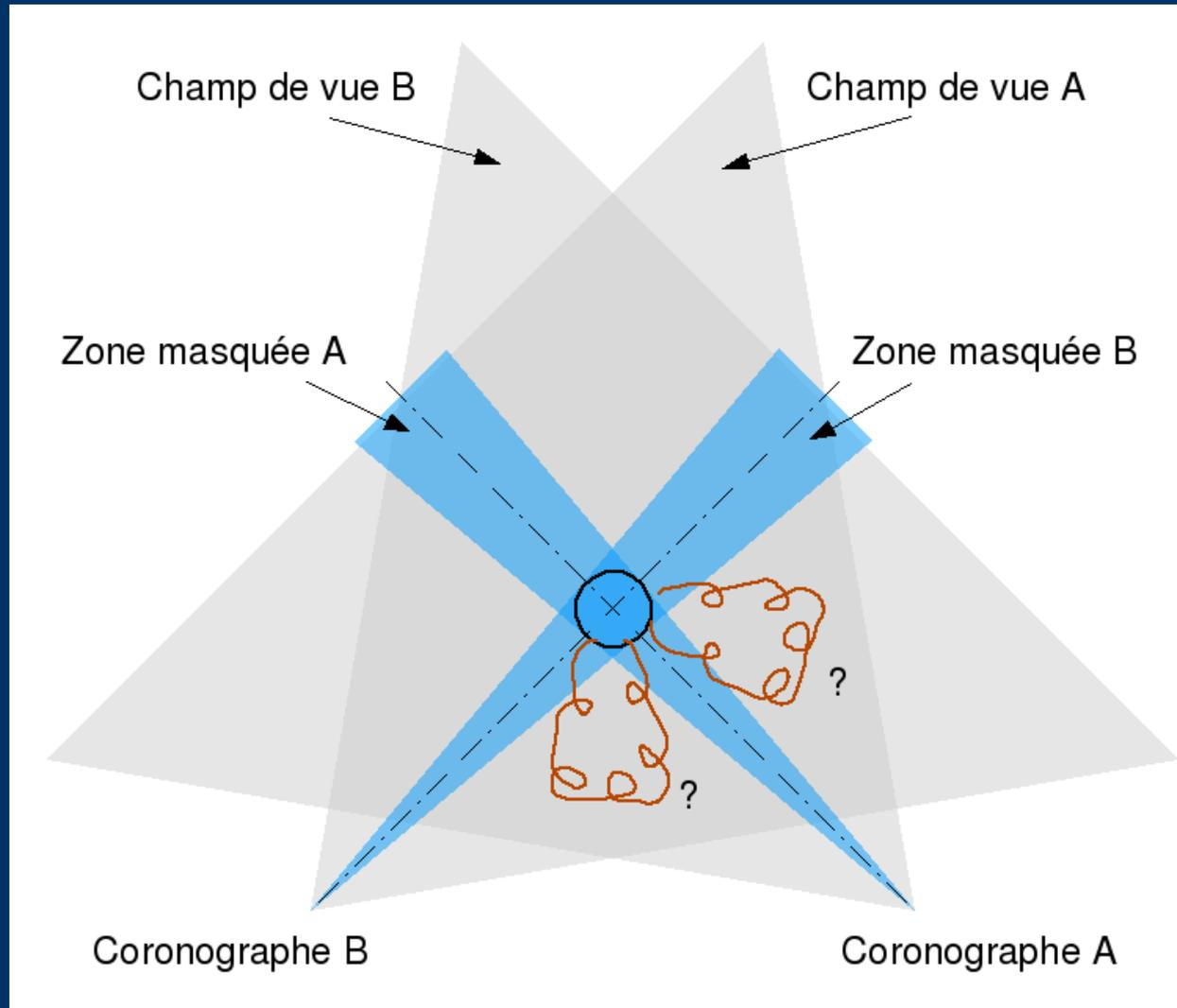

Observing a CME with STEREO-SECCHI

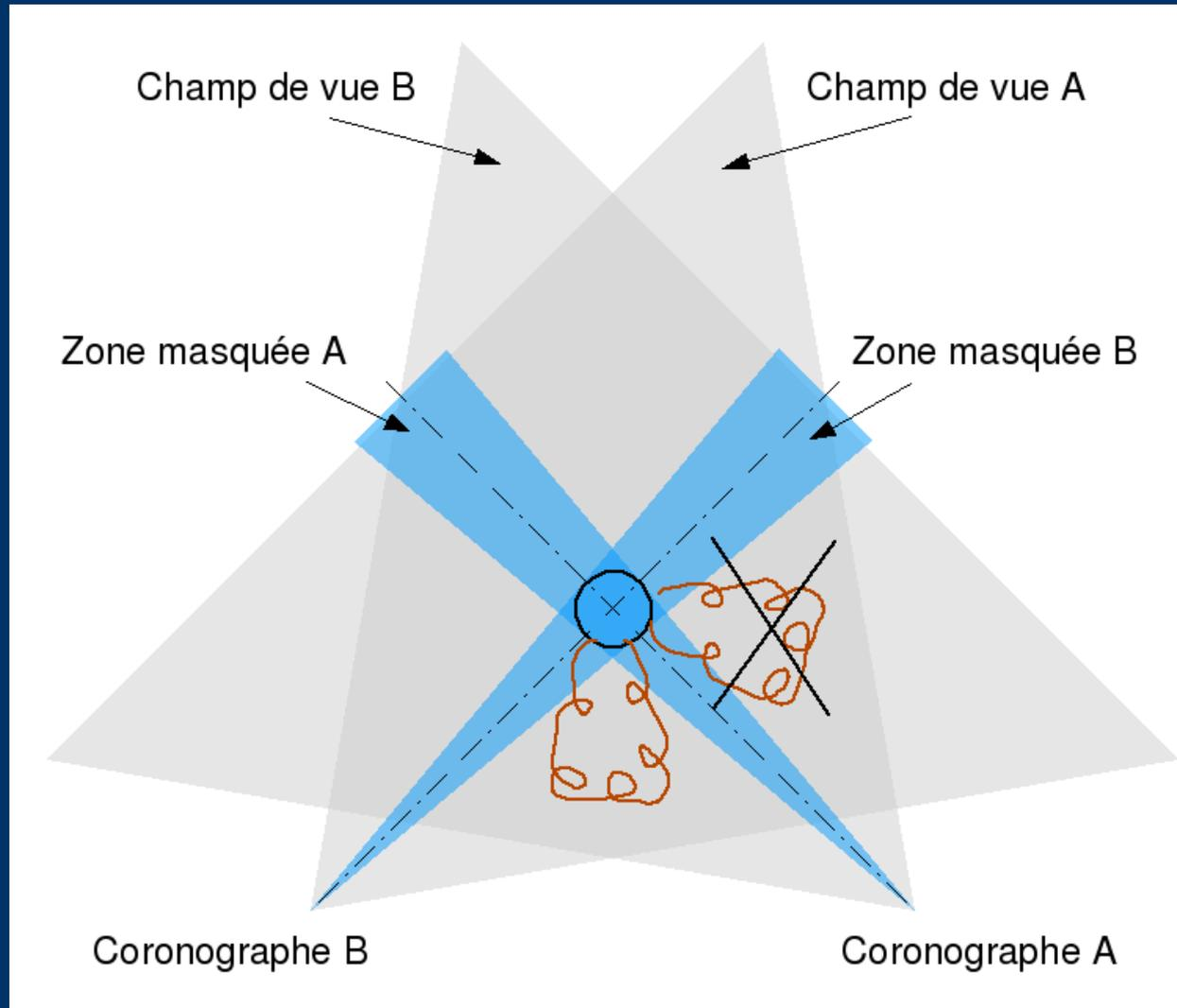

Observing a CME with STEREO-SECCHI

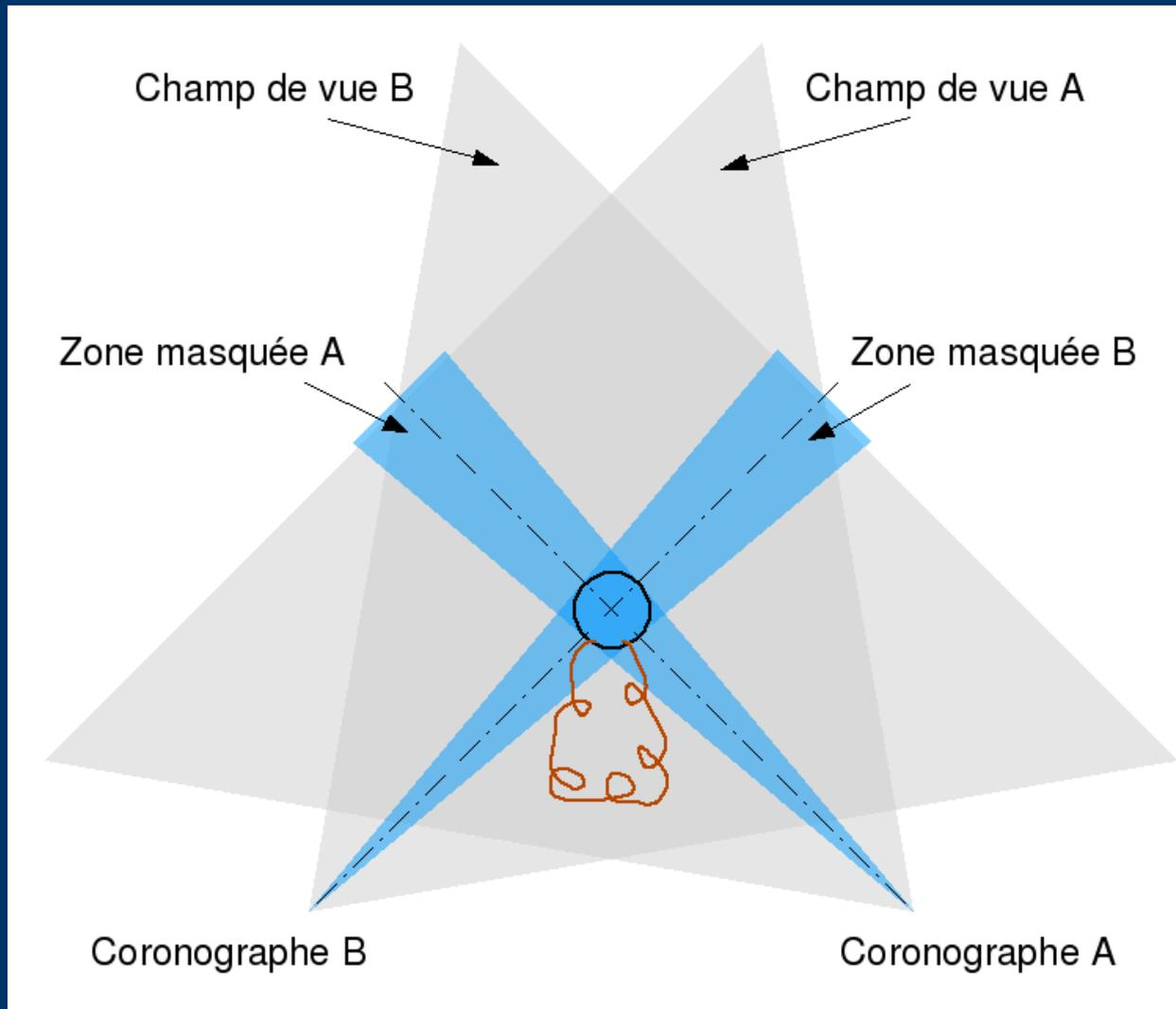

Event of 2007 Nov 16

Movie

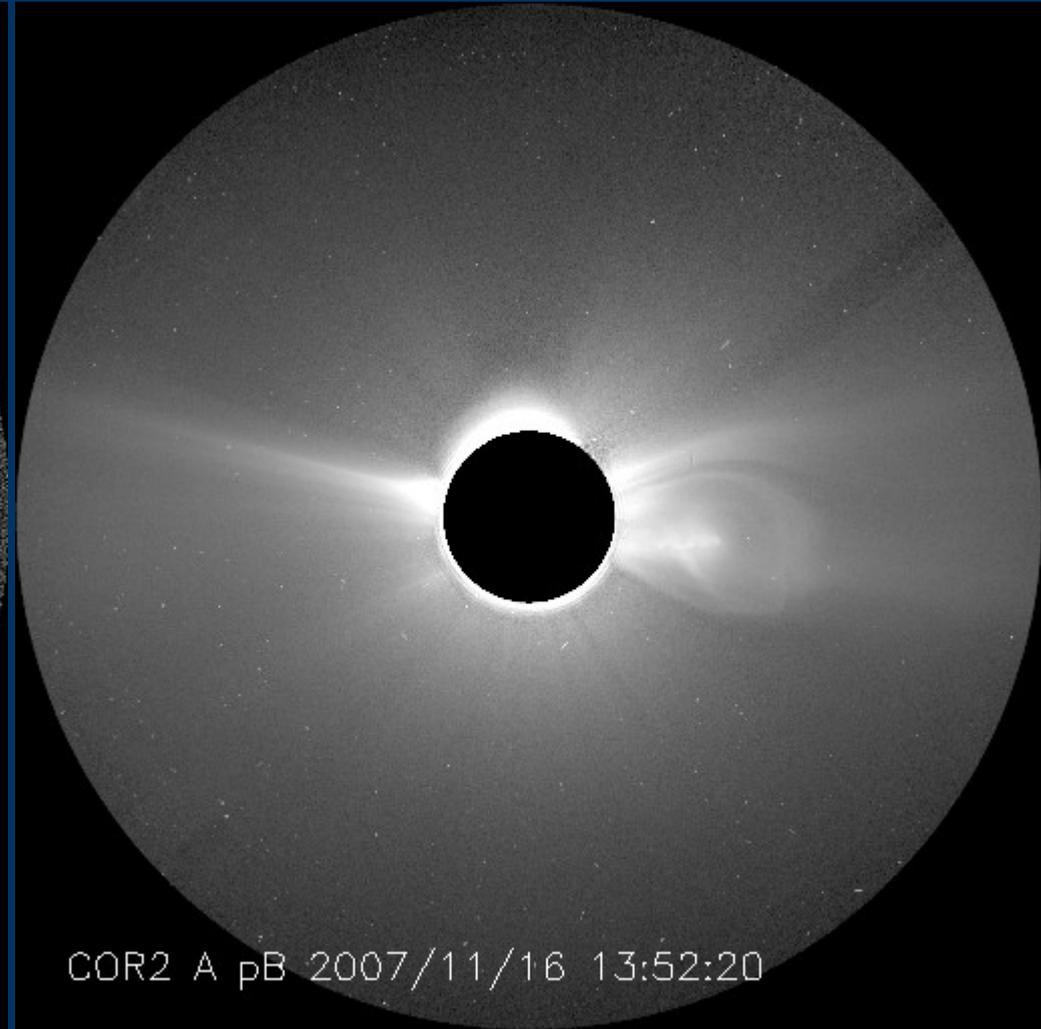
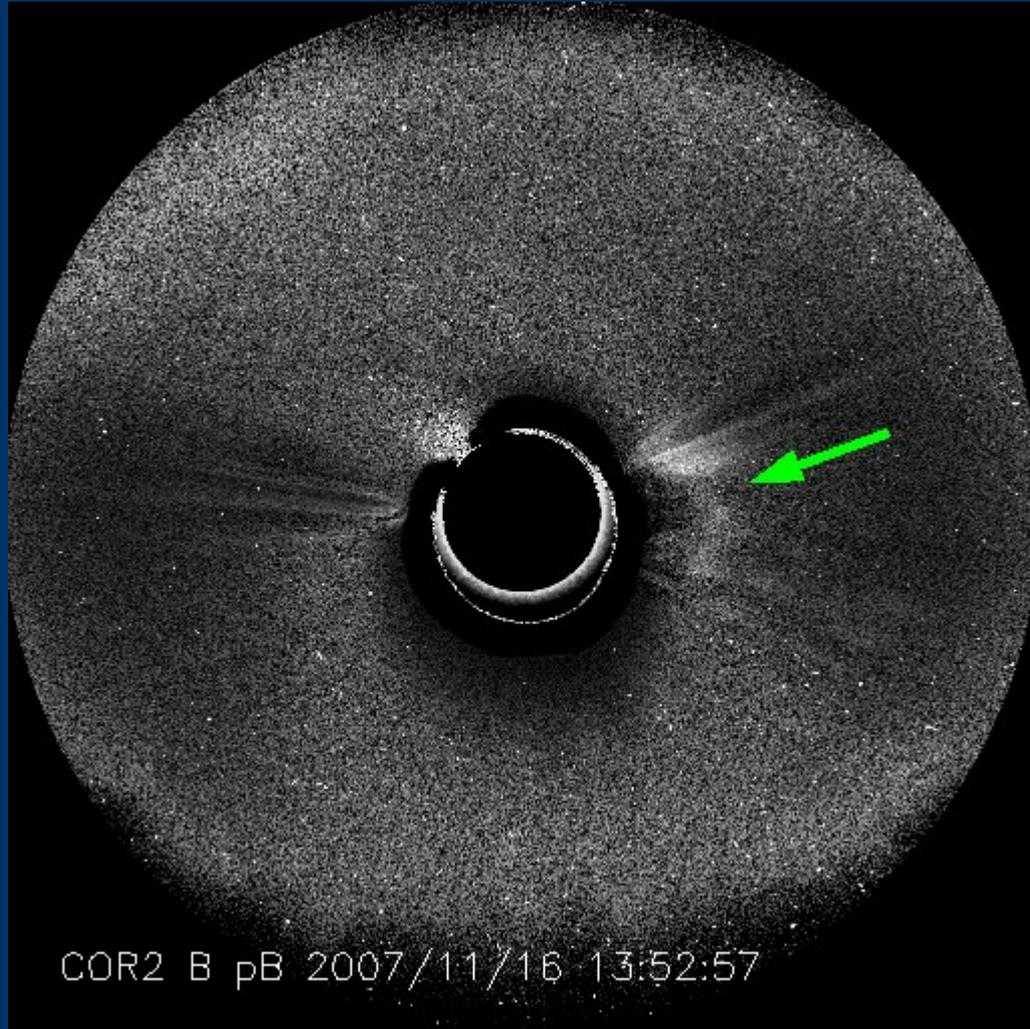

Event of 2007 Nov 16

Movie

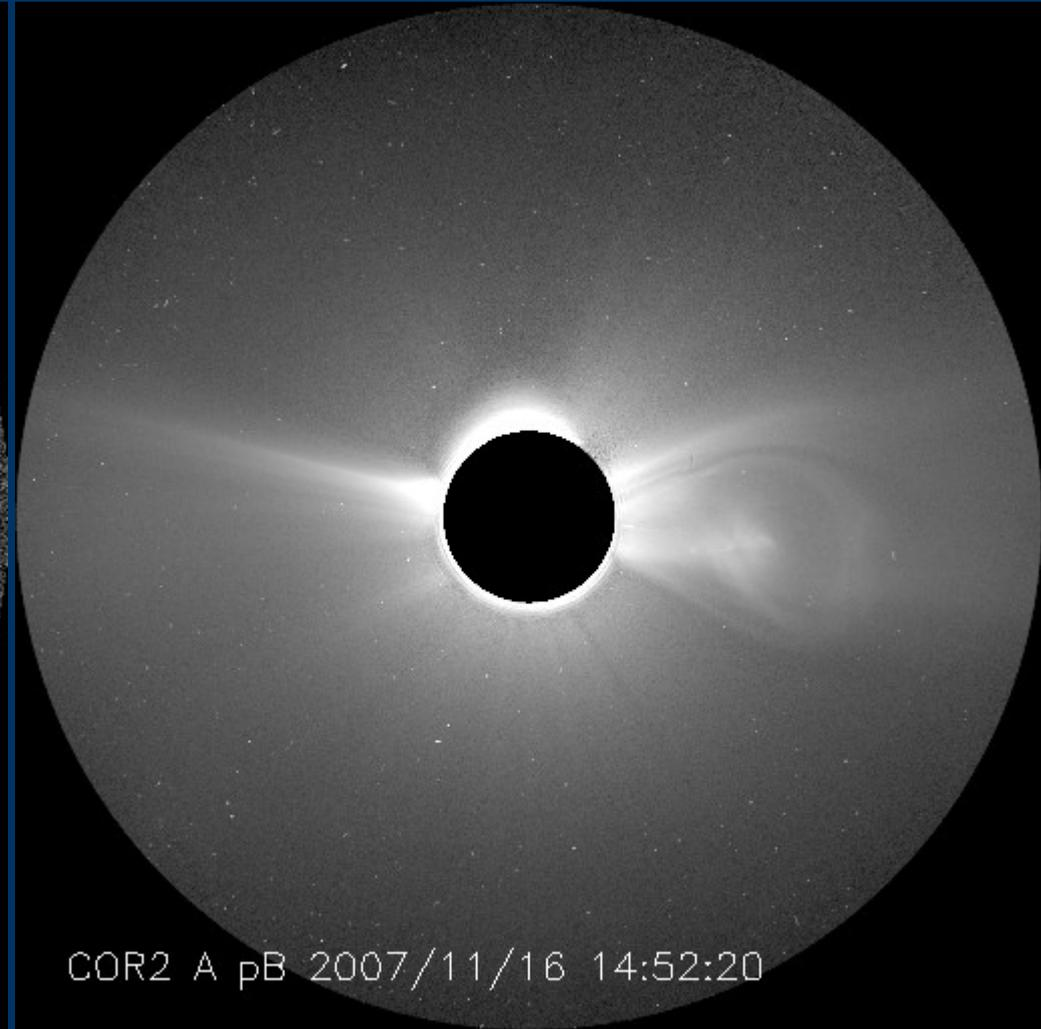
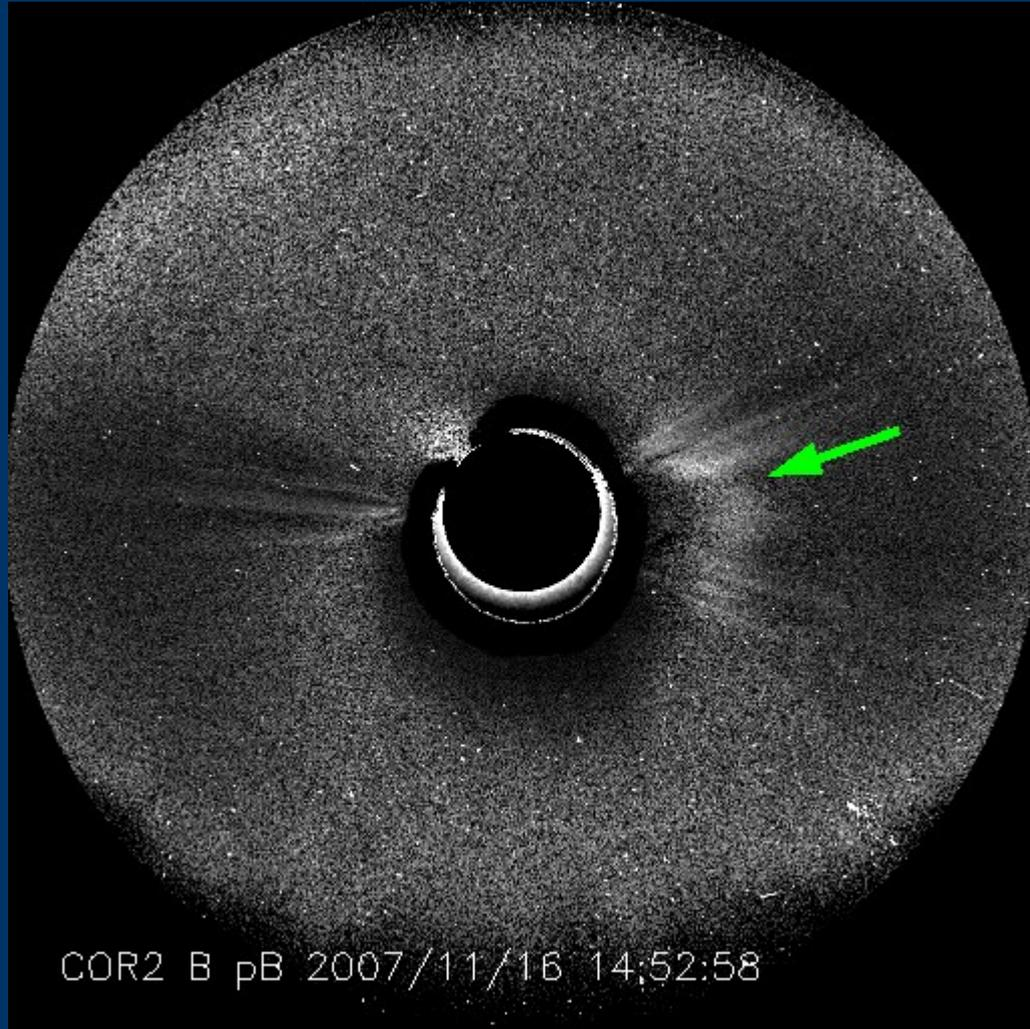

Event of 2007 Nov 16

Movie

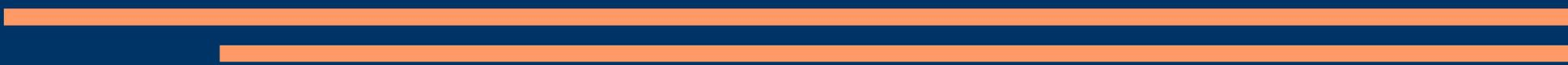
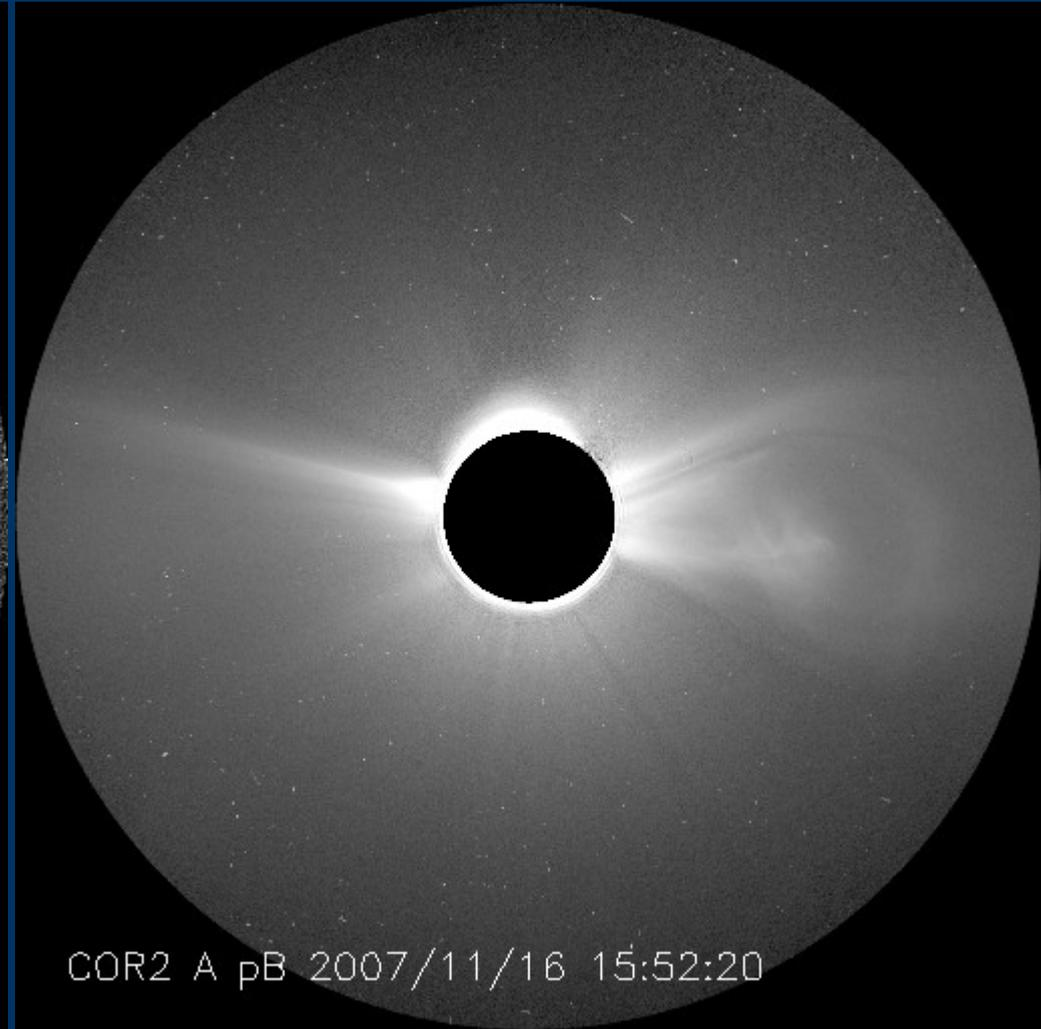
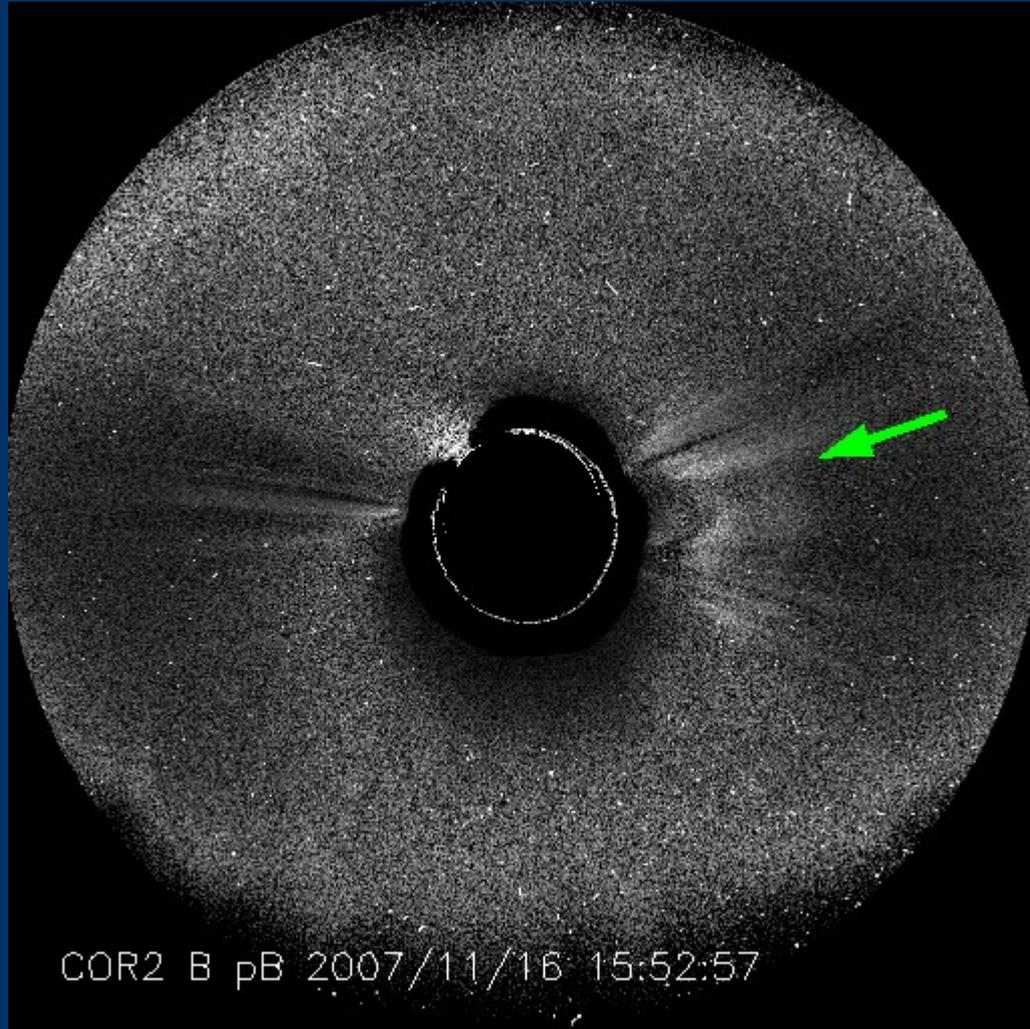

Event of 2007 Nov 16

Movie

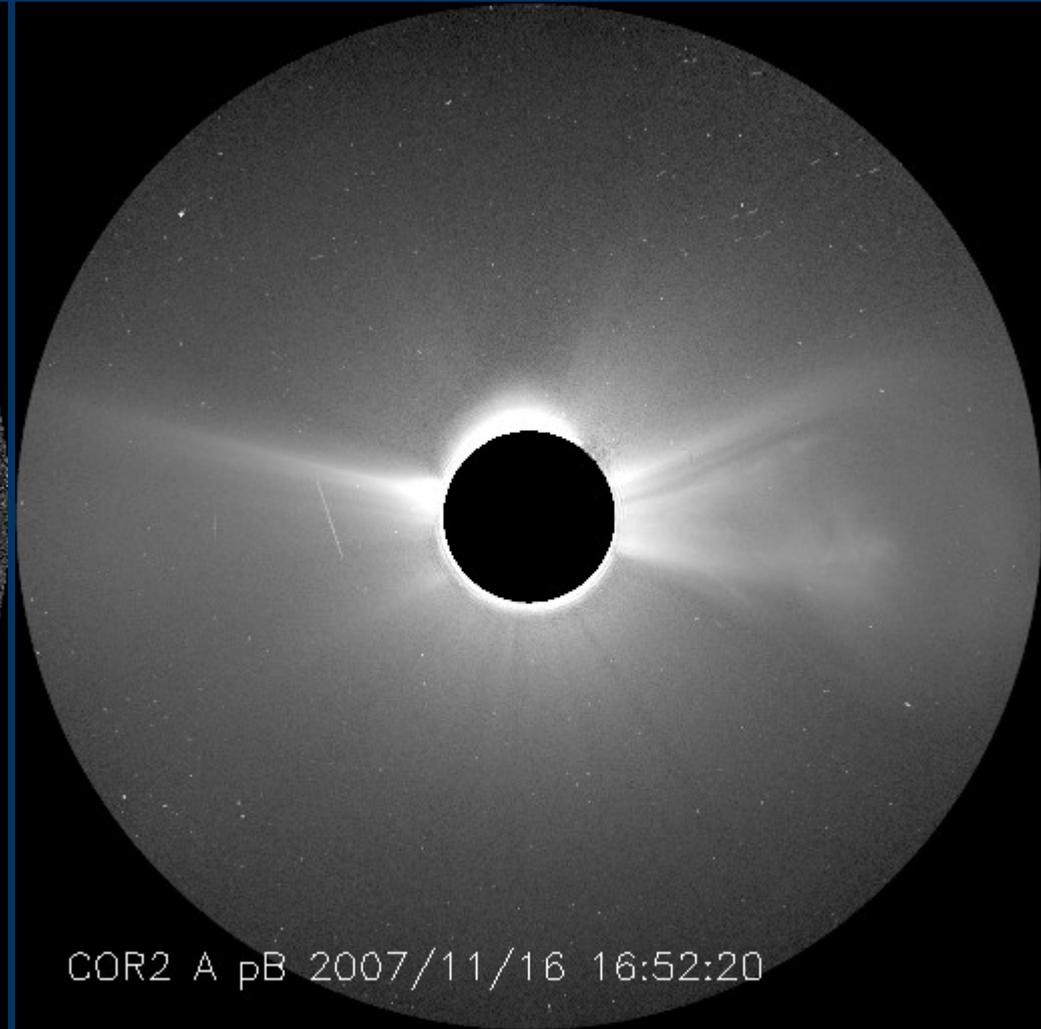
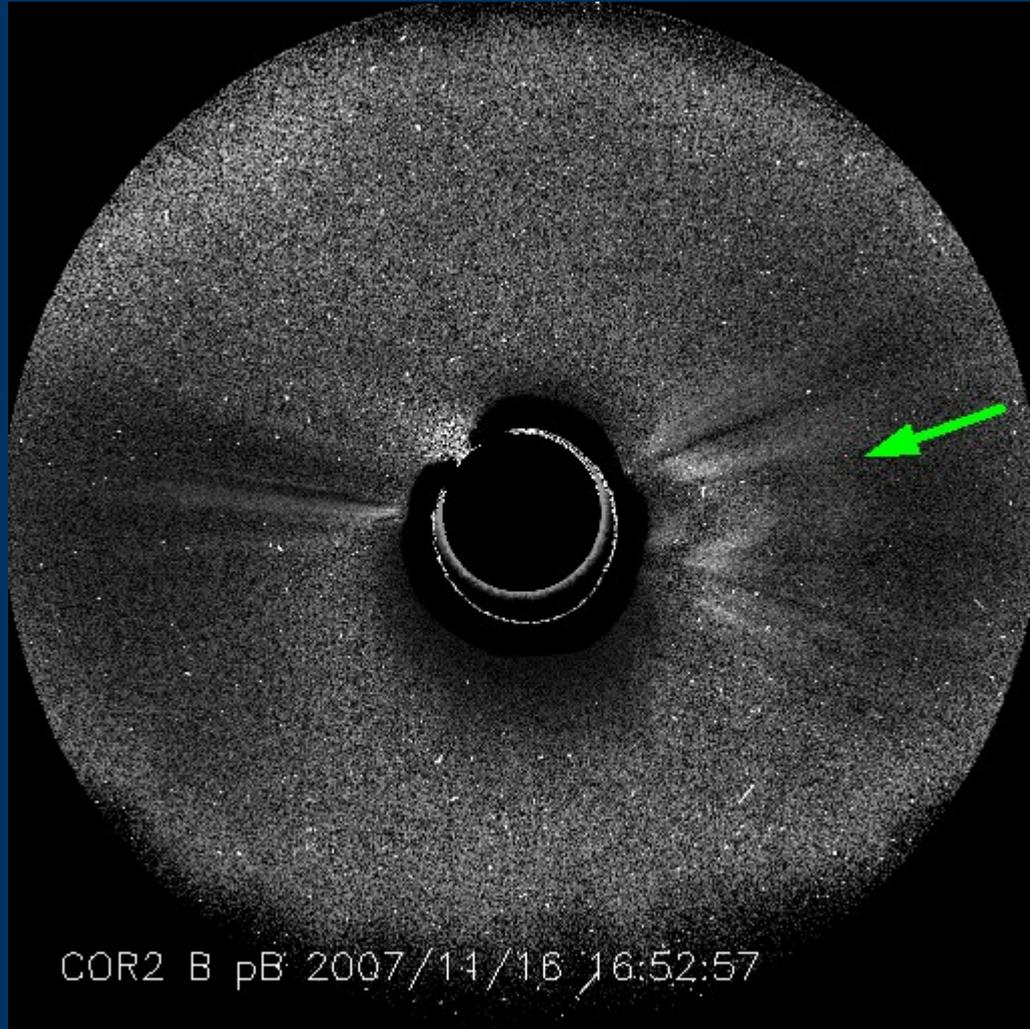

Event of 2007 Nov 16

Manual fit

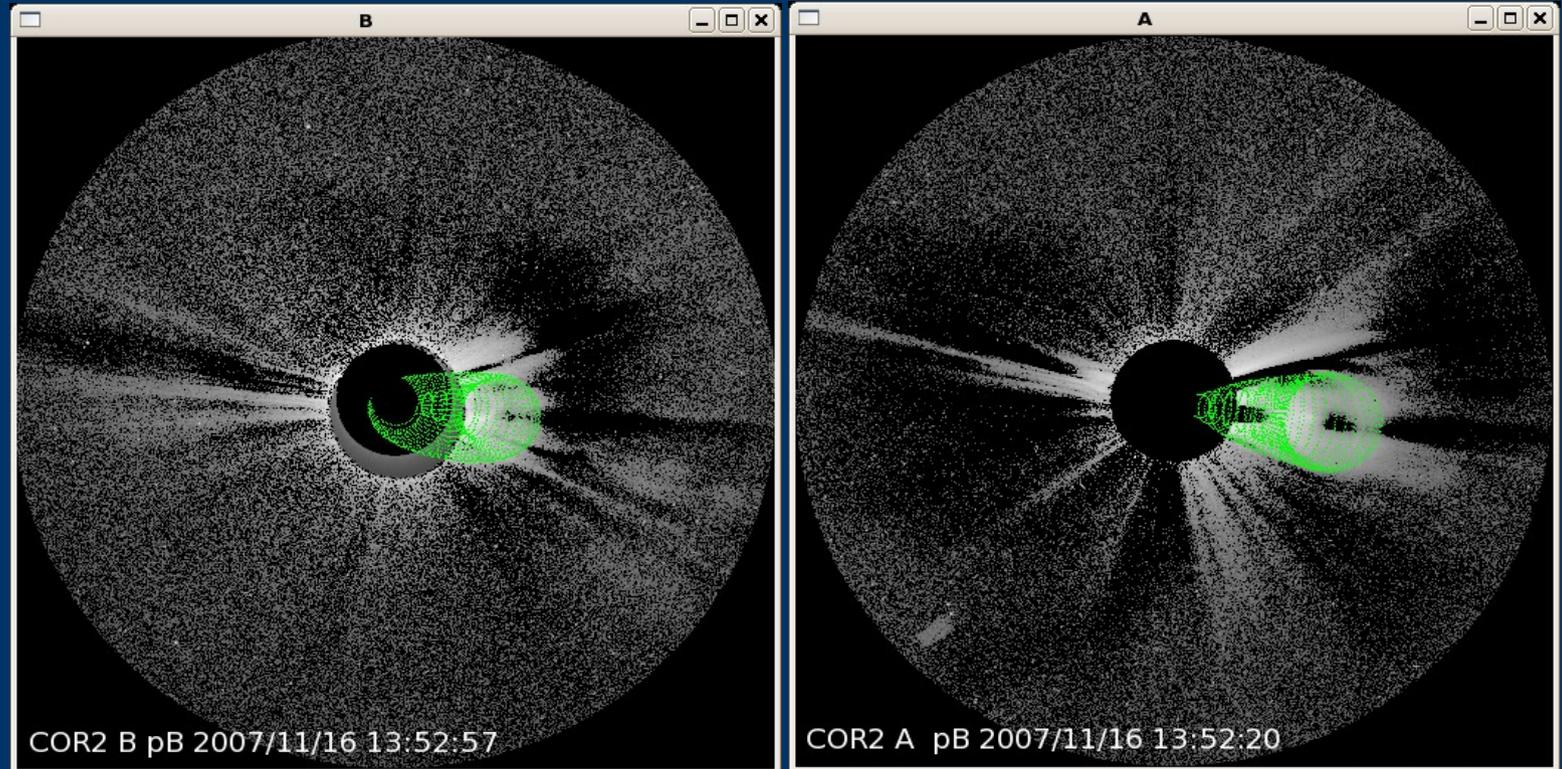

Event of 2007 Nov 16

Manual fit

STEREO Cloud

Position Cloud Simu

327.600

Longitude

-14.4018

Latitude

0.00000

Tilt Angle

6.32000

Height

0.307000

Ratio

20.7000

Half Angle

Eruption Date

2007-11-16T16:22:20.009

SC-A LON: -141.6 , LAT: 0.1
Date Obs: 2007-11-16T16:22:20.009
SC-B LON: 178.2 , LAT: 5.1
Date Obs: 2007-11-16T16:22:57.663

Generate View

Quit

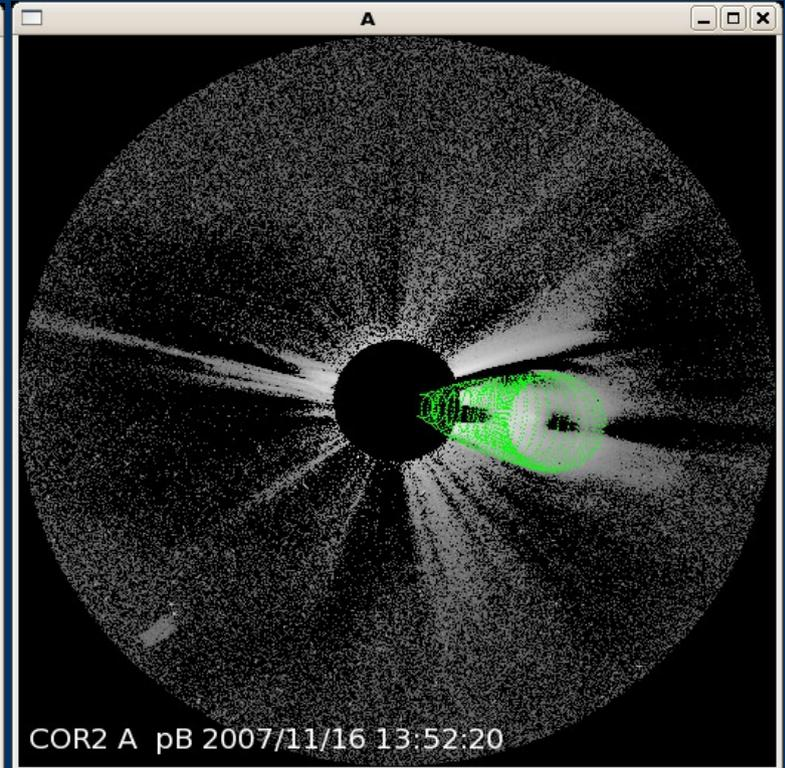
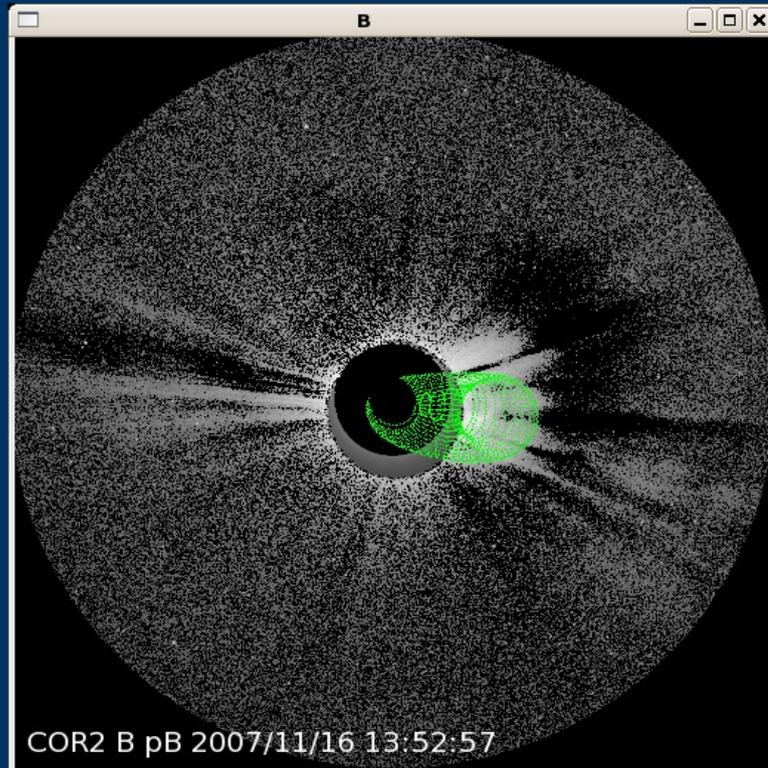

Event of 2007 Nov 16

Manual fit

STEREO Cloud

Position Cloud Simu

327.600

Longitude

-14.4018

Latitude

0.00000

Tilt Angle

6.32000

Height

0.307000

Ratio

20.7000

Half Angle

Eruption Date

2007-11-16T16:22:20.009

SC-A LON: -141.6 , LAT: 0.1
Date Obs: 2007-11-16T16:22:20.009
SC-B LON: 178.2 , LAT: 5.1
Date Obs: 2007-11-16T16:22:57.663

Generate View

Quit

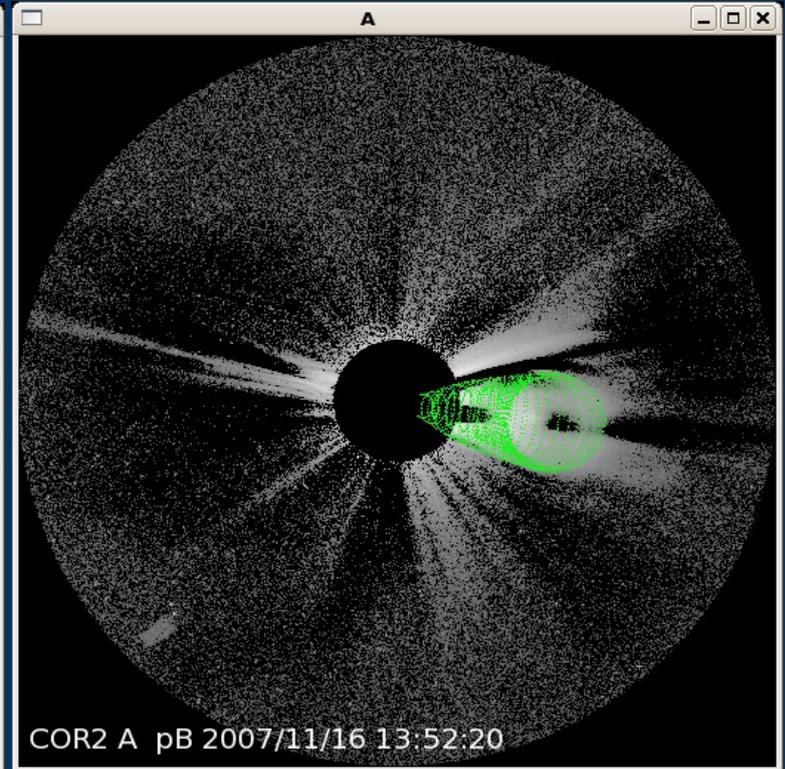
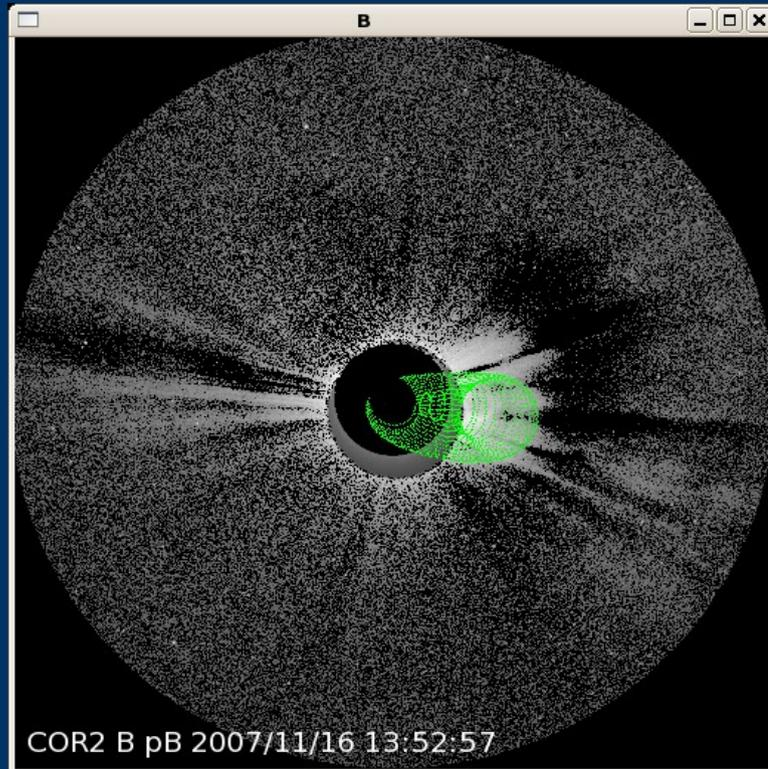

Available in SolarSoft. Try:

IDL> rtsccloud, /demo

Event of 2007 Nov 16

Height / Time plot

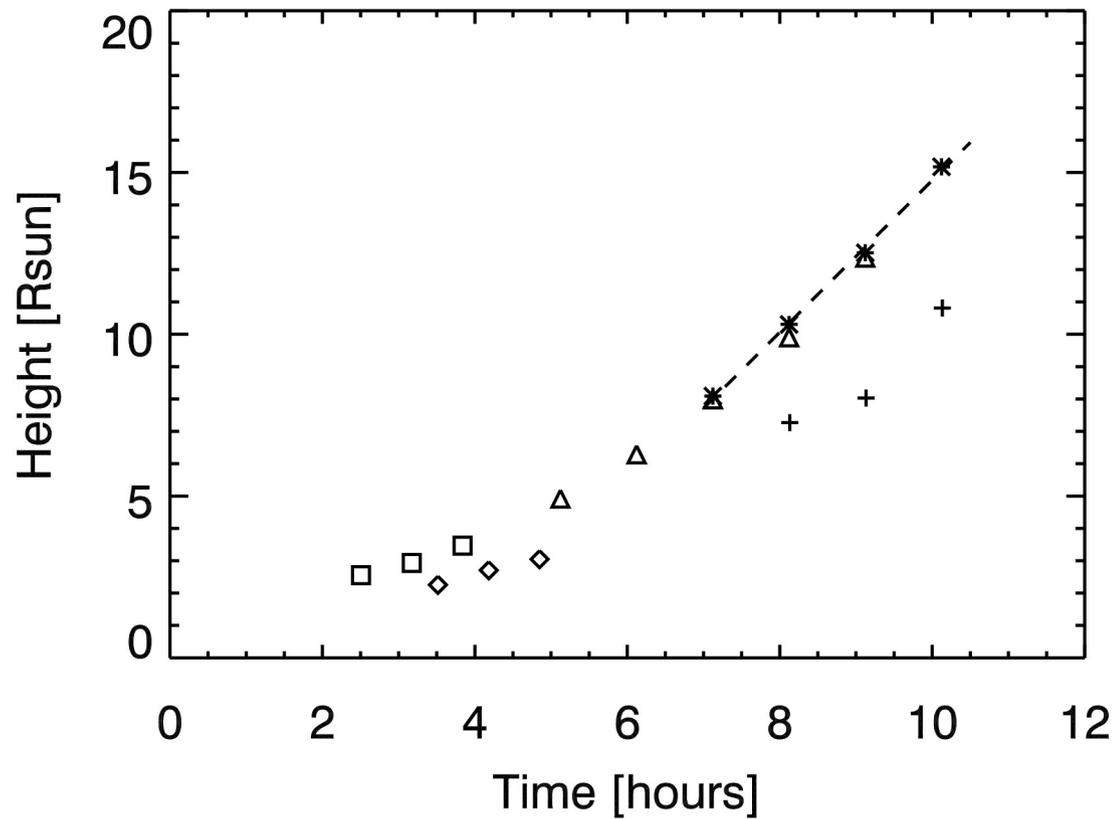

Event of 2007 Nov 16

Position

Paramètre	Valeur
Longitude Carrington	331.2°
Latitude Carrington	-14.4°
Angle d'inclinaison γ	3.6°
Hauteur du front	15.2 R_{\odot}
Rapport d'aspect κ	0.3
Demi-angle α	27°

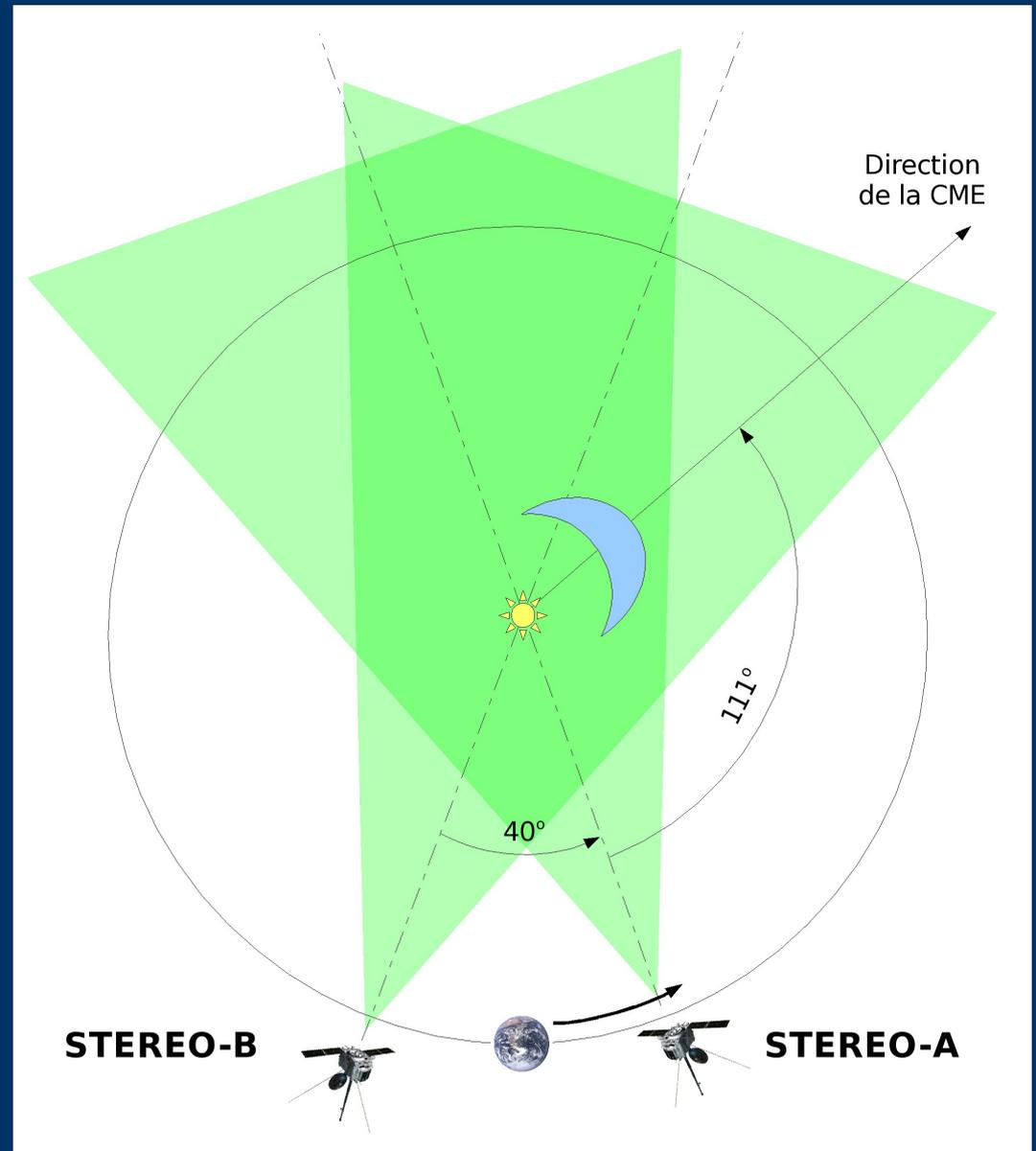

Event of 2008 Apr 05

Movie

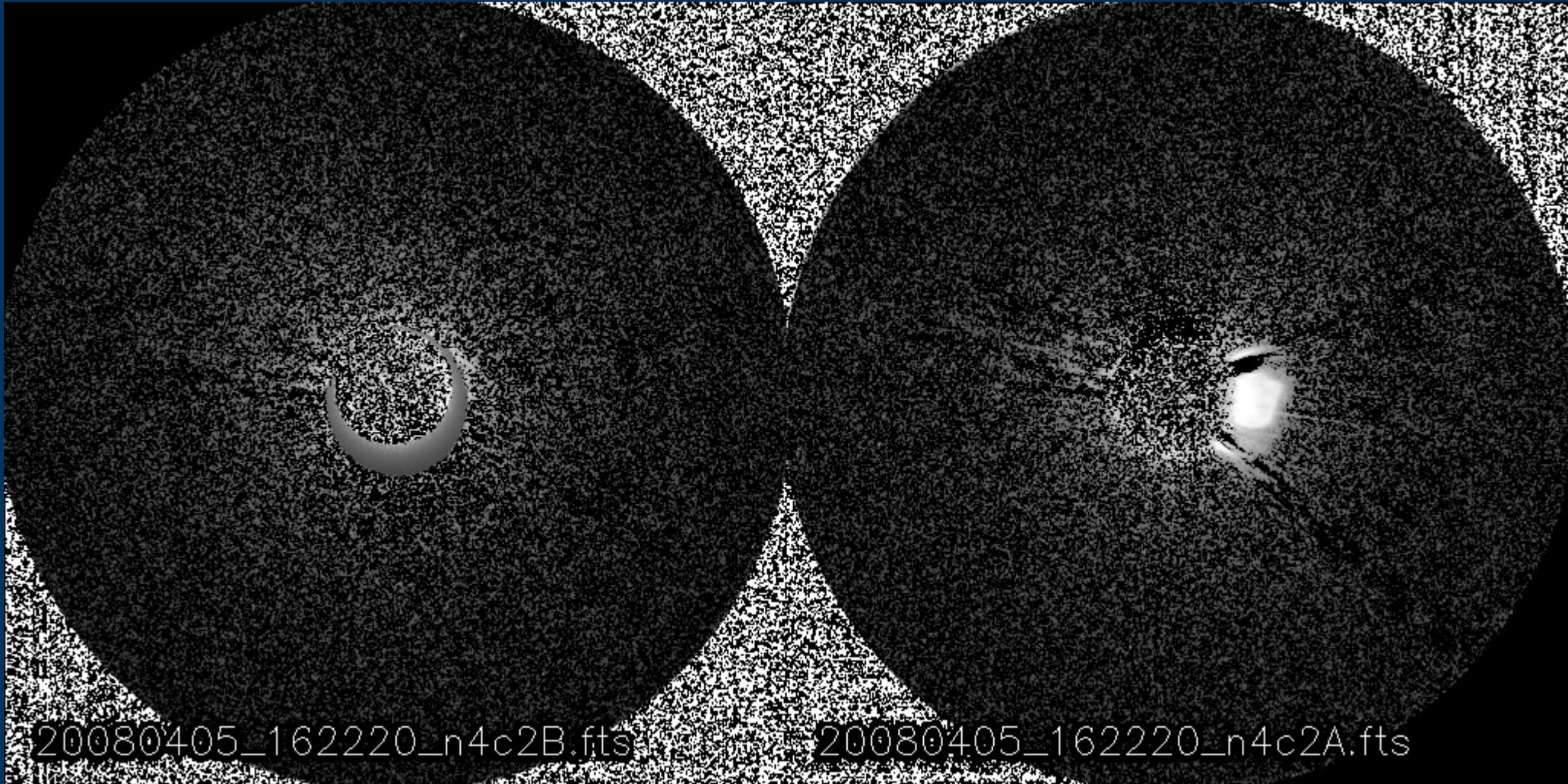

20080405_162220_n4c2B.fts

20080405_162220_n4c2A.fts

Event of 2008 Apr 05

Movie

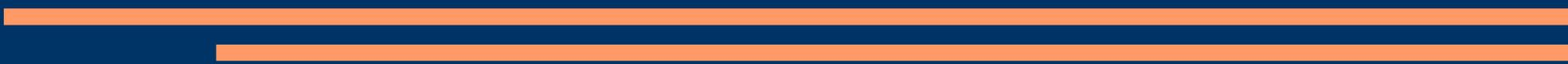
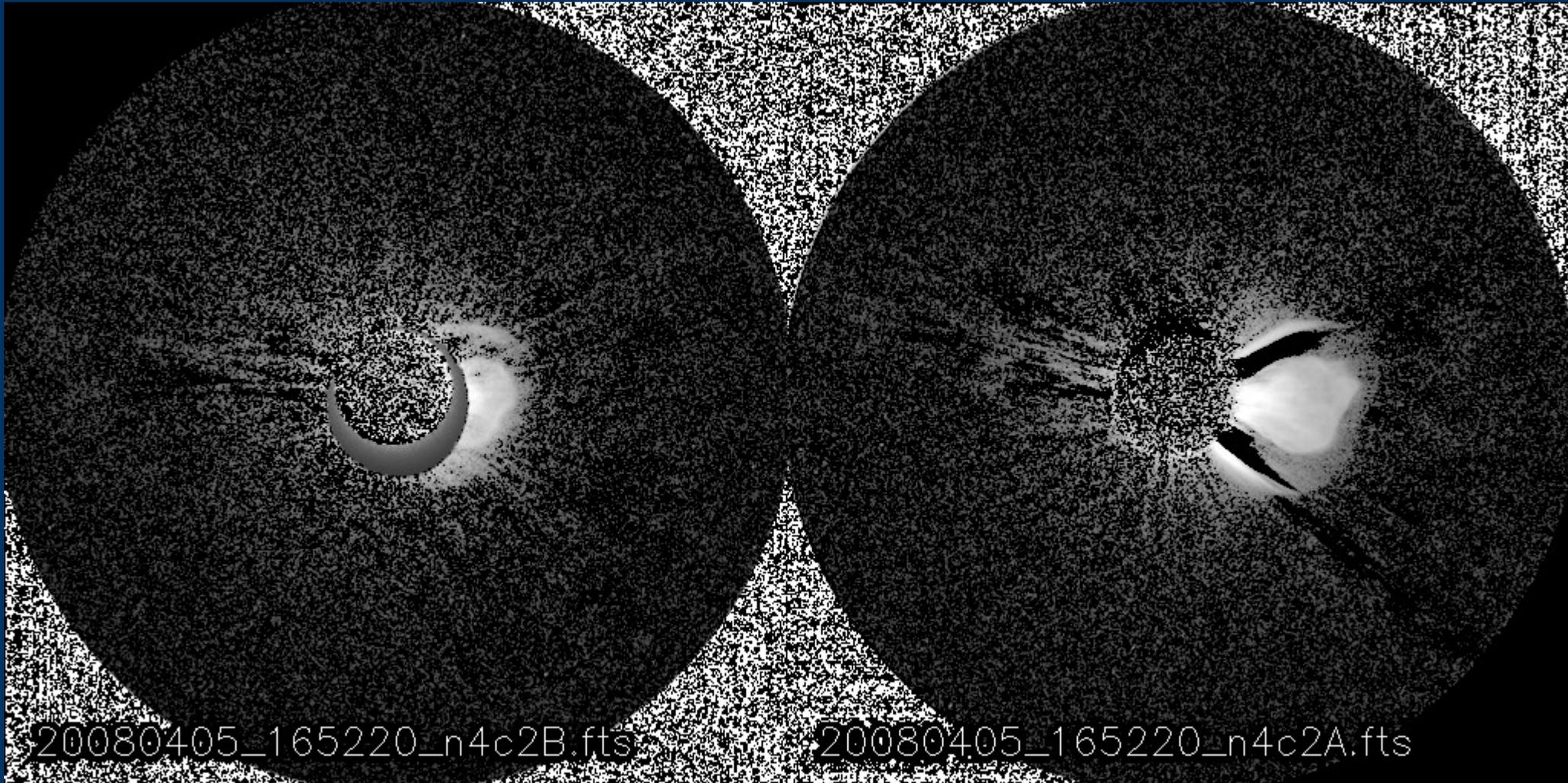

Event of 2008 Apr 05

Movie

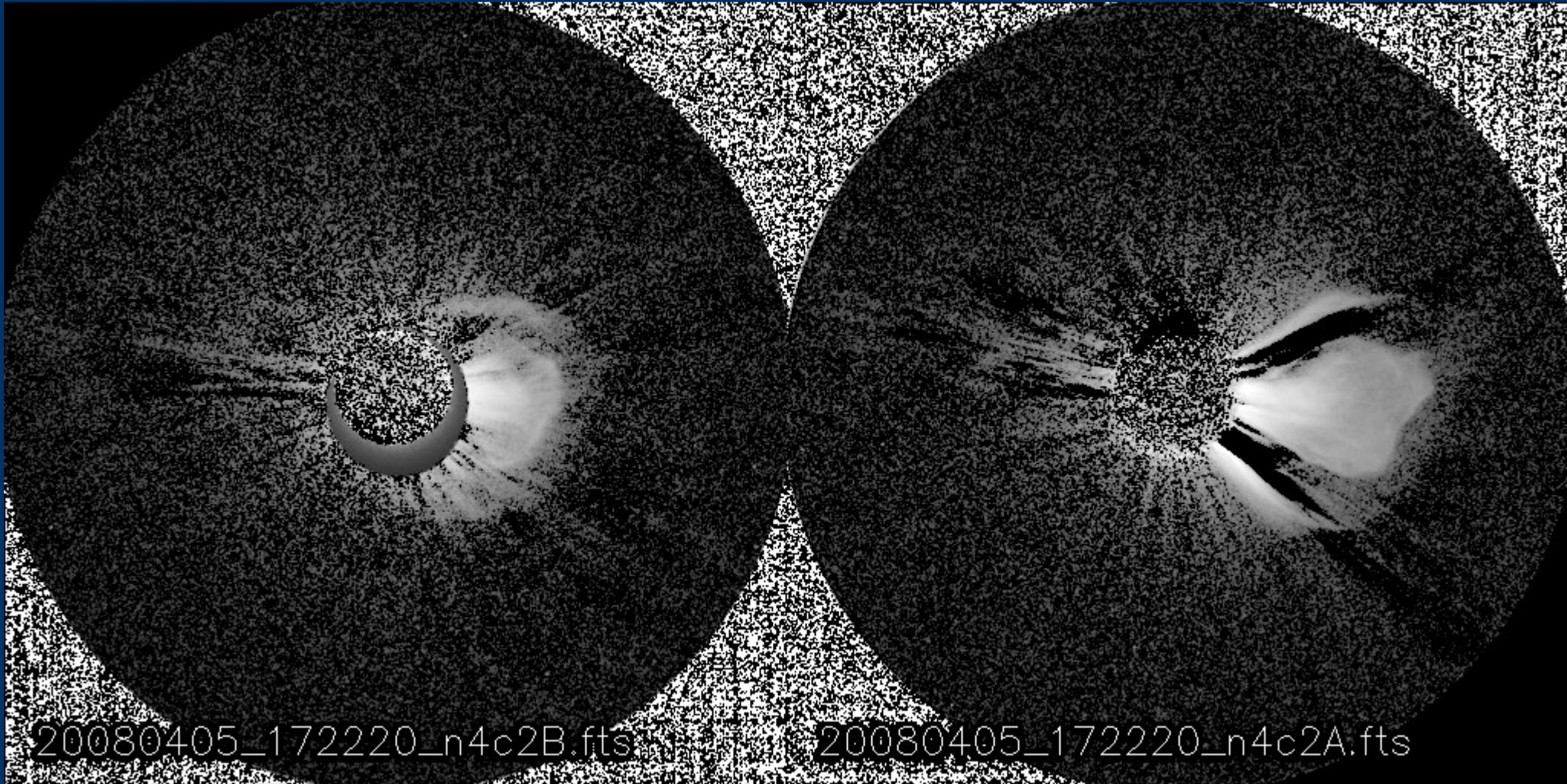

Event of 2008 Apr 05

Movie

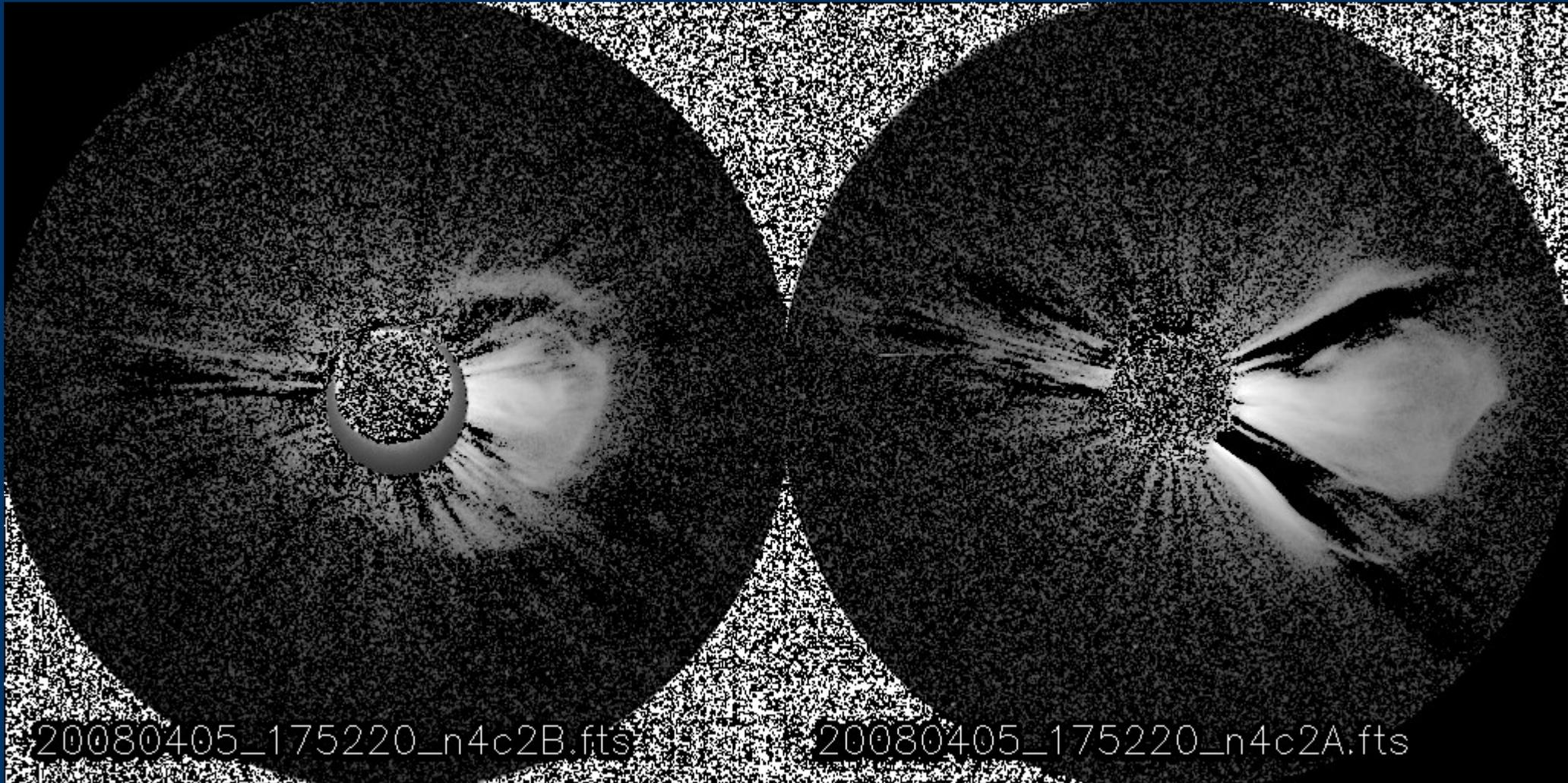

Event of 2008 Apr 05

Movie

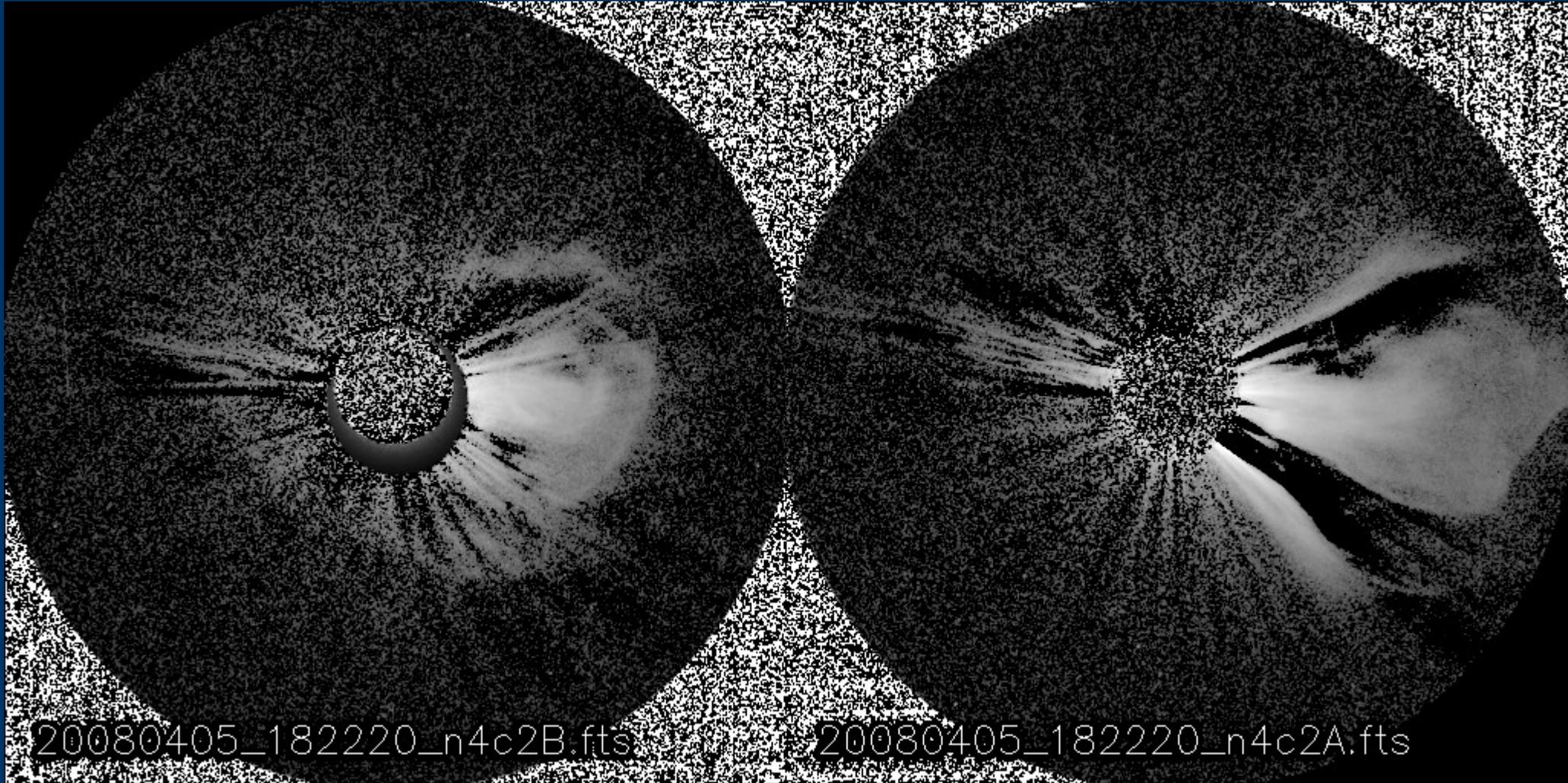

20080405_182220_n4c2B.fits

20080405_182220_n4c2A.fits

Event of 2008 Apr 05

Movie

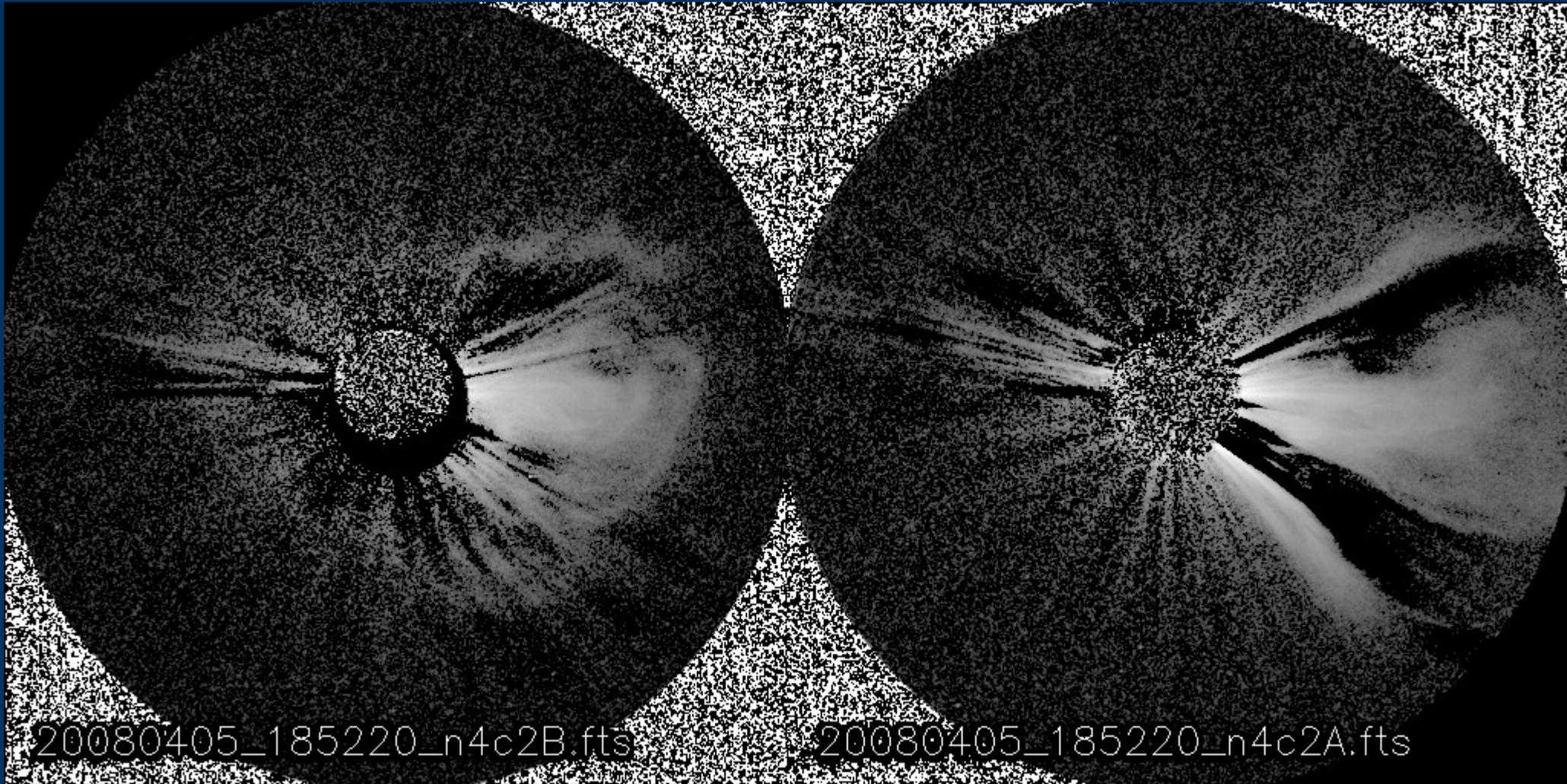

20080405_185220_n4c2B.fits

20080405_185220_n4c2A.fits

Event of 2008 Apr 05

Movie

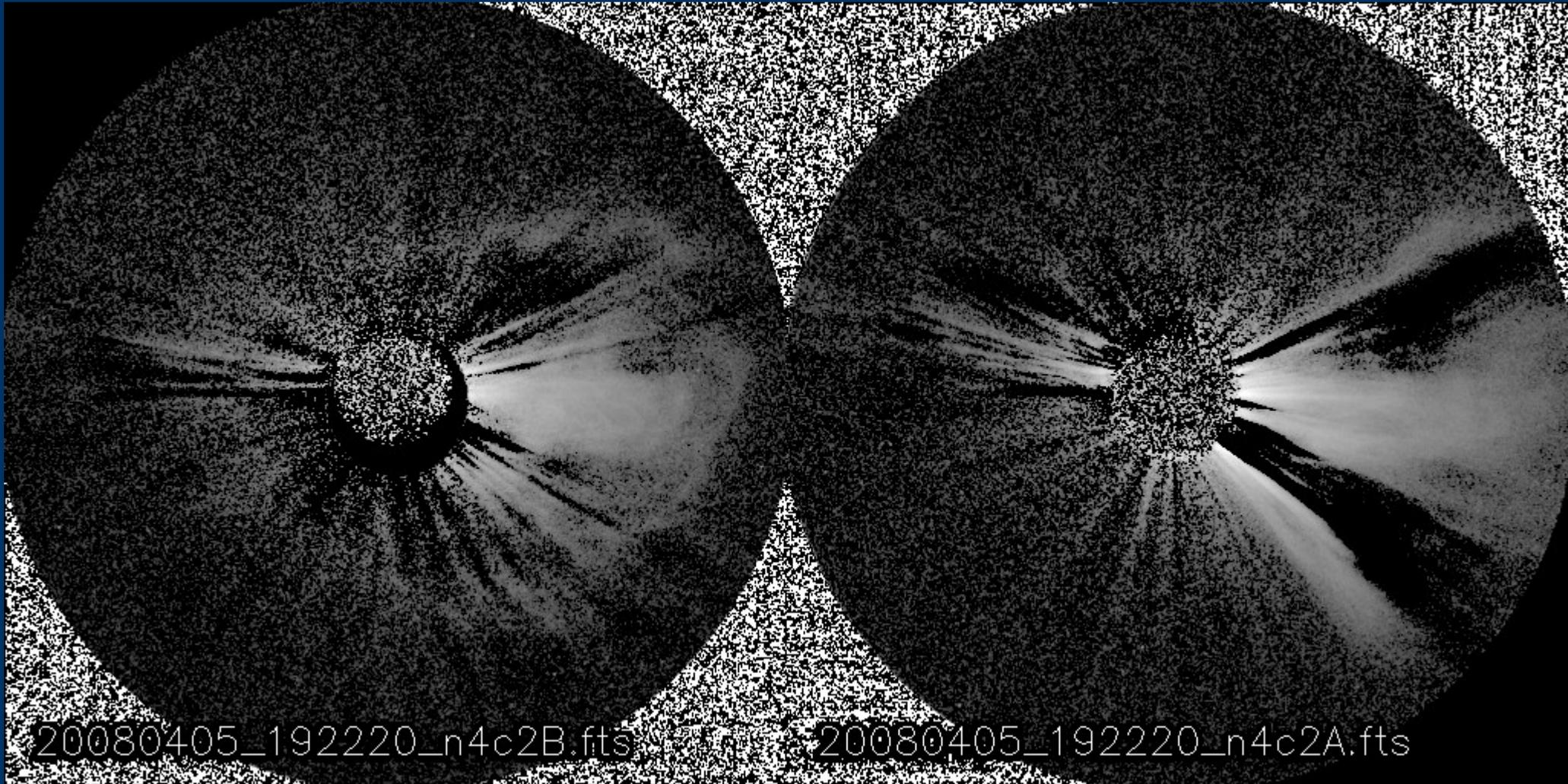

20080405_192220_n4c2B.fts

20080405_192220_n4c2A.fts

Event of 2008 Apr 05

Fit

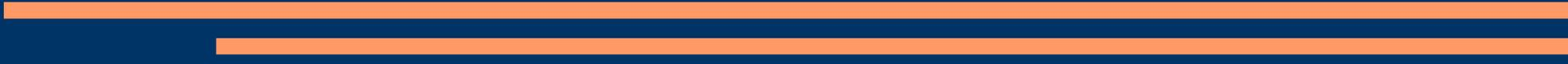
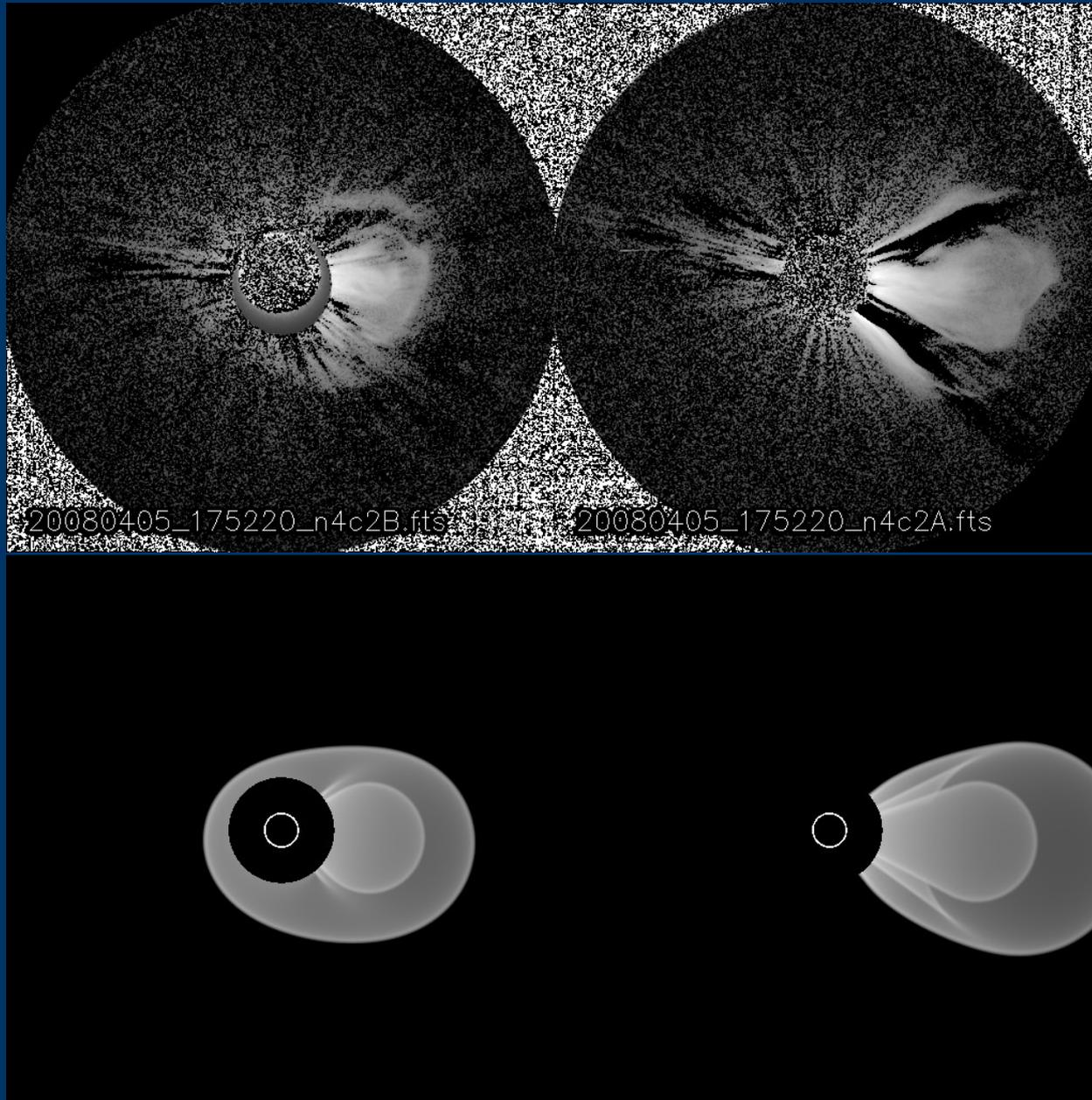

Event of 2008 Apr 05

Direction

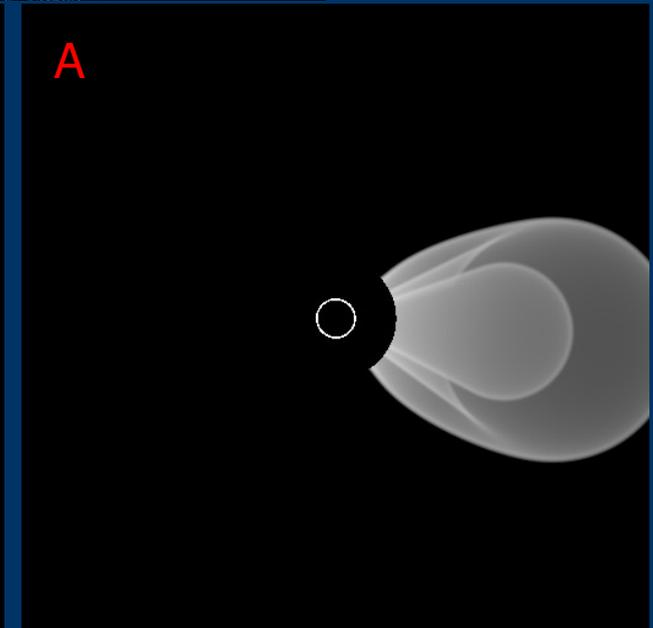
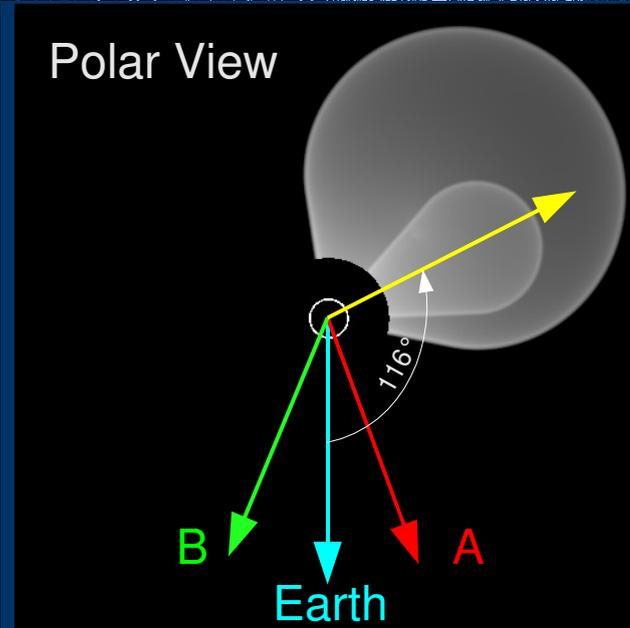
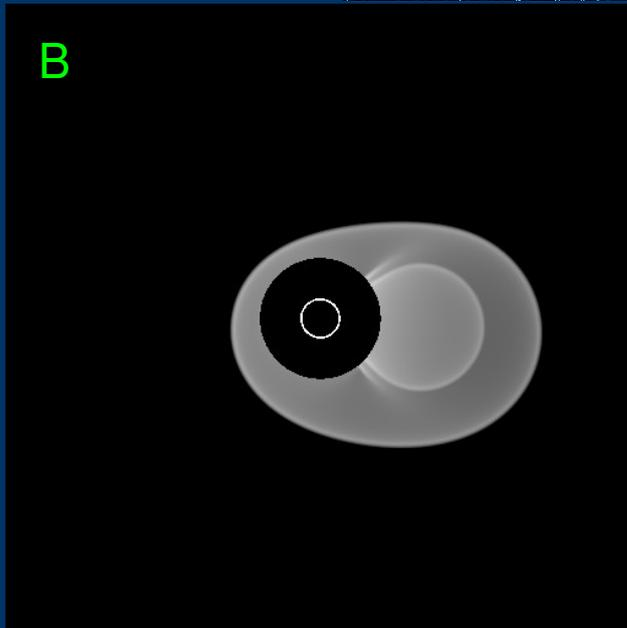
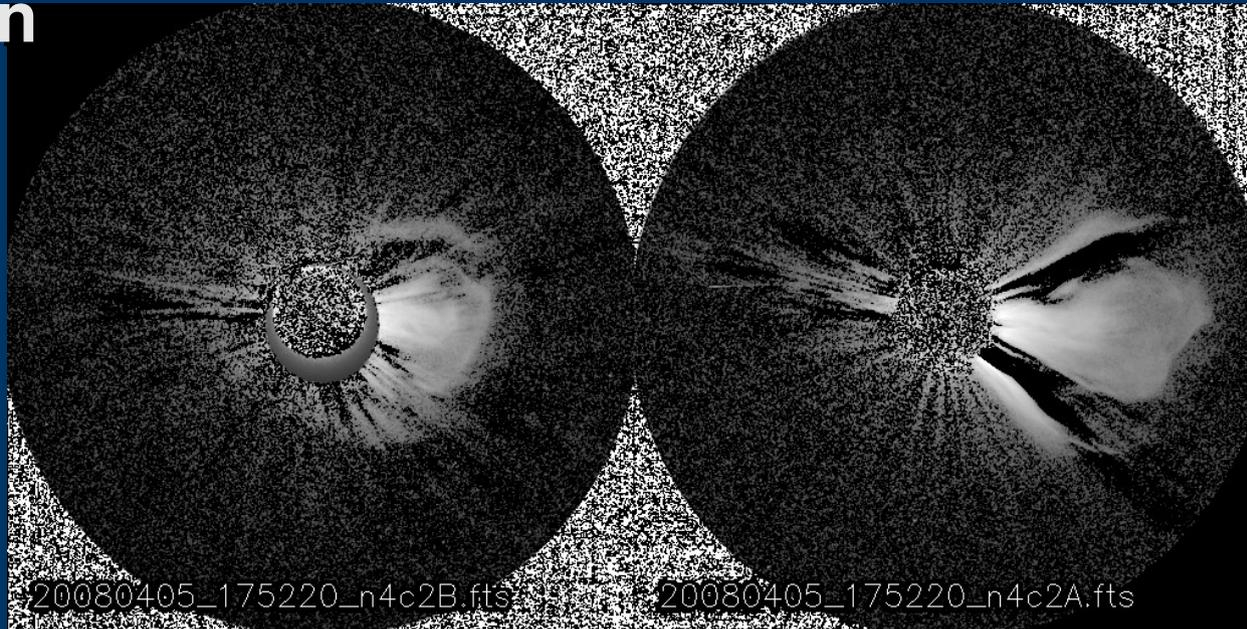

Summary for the 14 studied CMEs

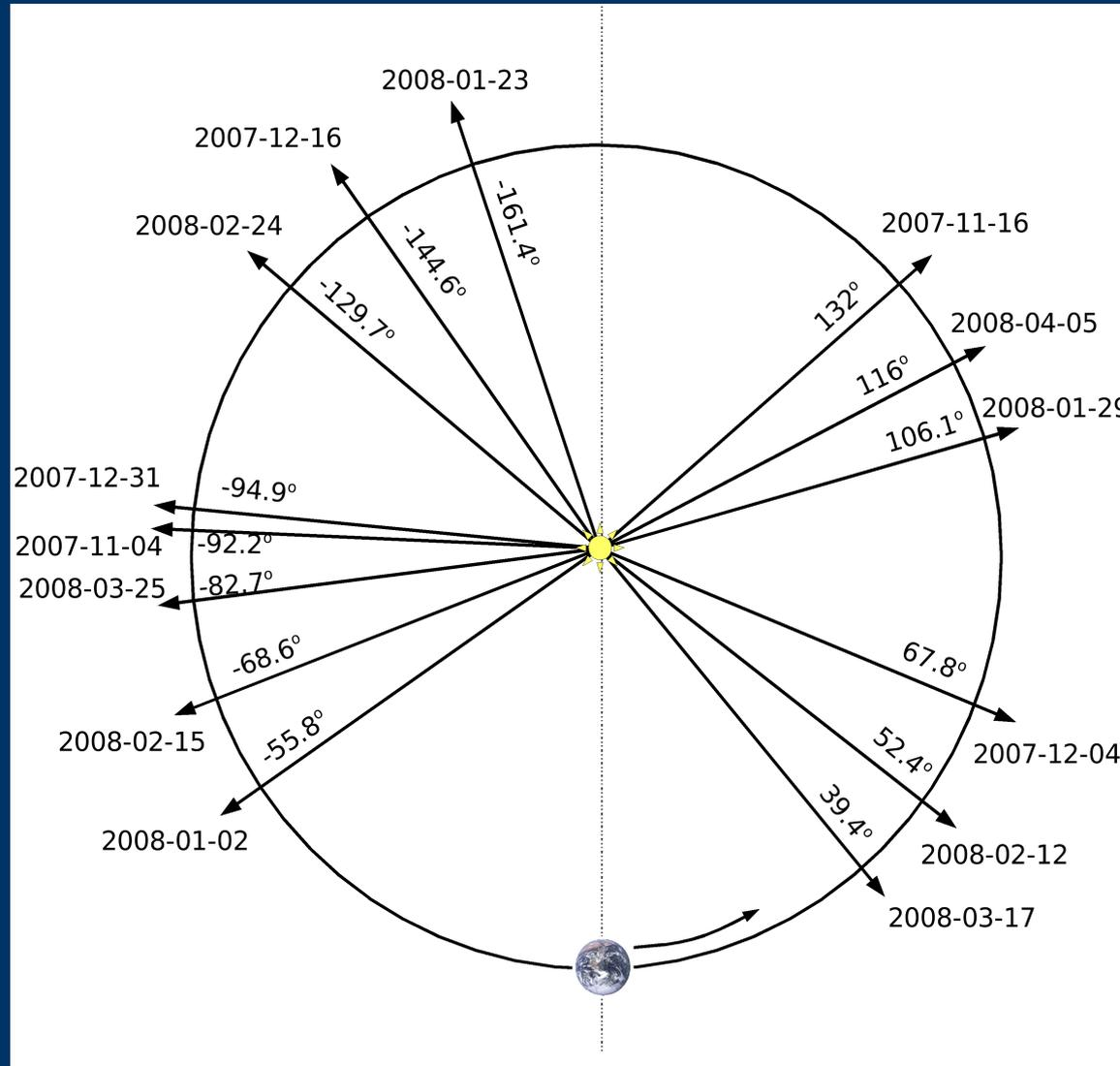

Summary

- Separation > 40 Deg: it's possible now to determine the CME true direction and speed.
 - 14 CMEs studied so far: waiting for more !
 - Earth directed CMEs ?
 - Future:
 - Extend SECCHI CACTUS CME catalog with the model parameter fit.
 - Determine the Ne in regions of interest.
-
-

Fin



Junk slides



Sensitivity Analysis

- Depth.
- Angular extent.
-



Modeling of Flux-Rope CMEs

Application to LASCO C2 Events

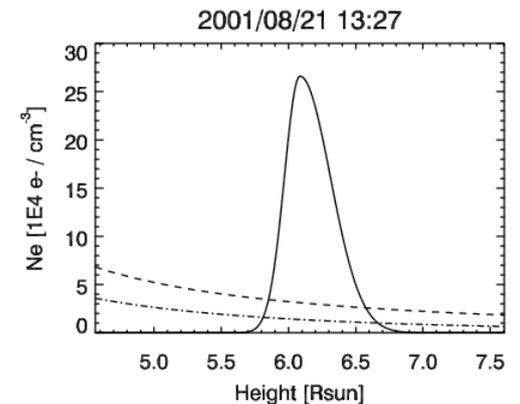
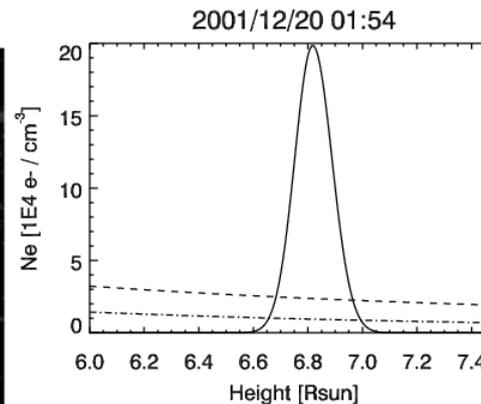
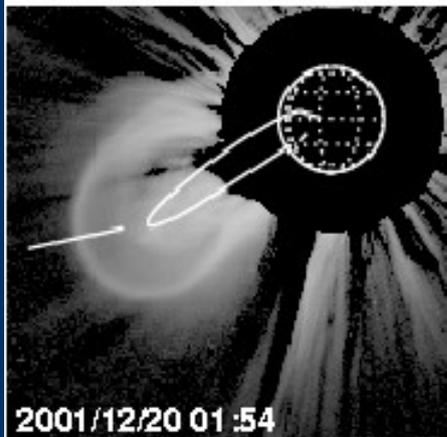
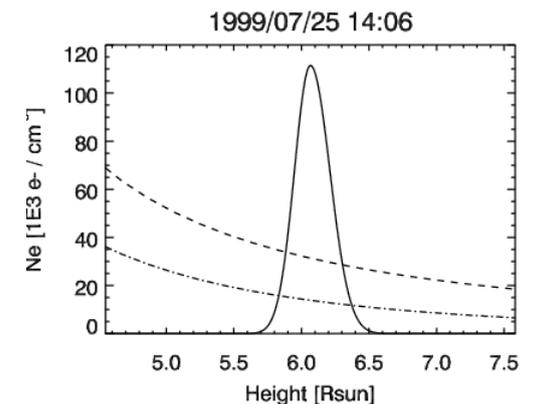
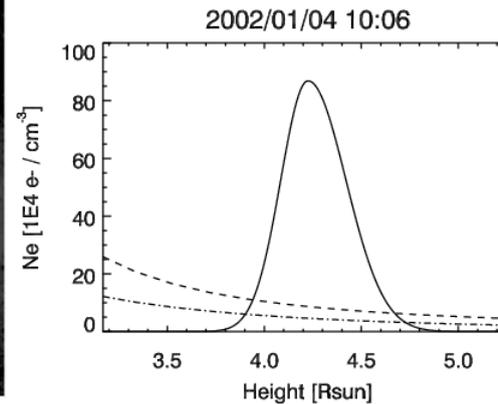
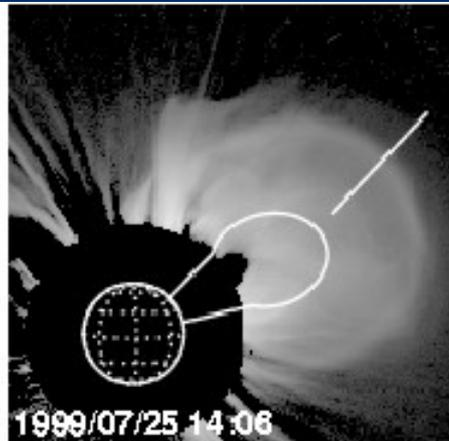

Cremades & Bothmer, 2004, Thernisien, Howard & Vourlidas, 2006

Modeling of Flux-Rope CMEs

Application to LASCO C2 Events

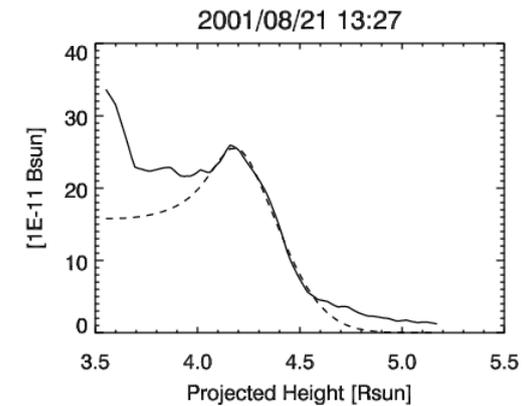
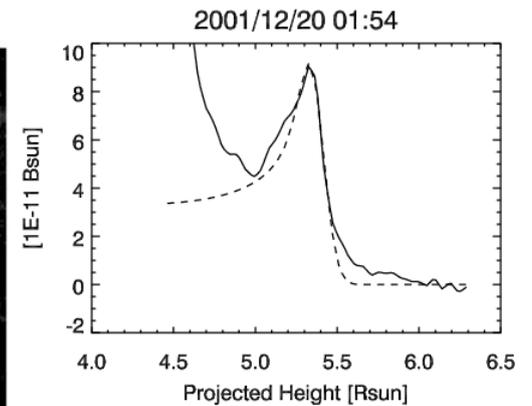
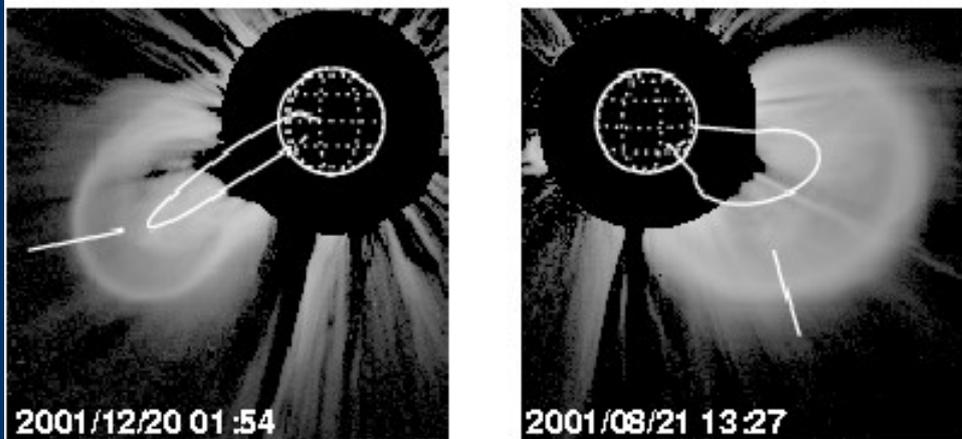
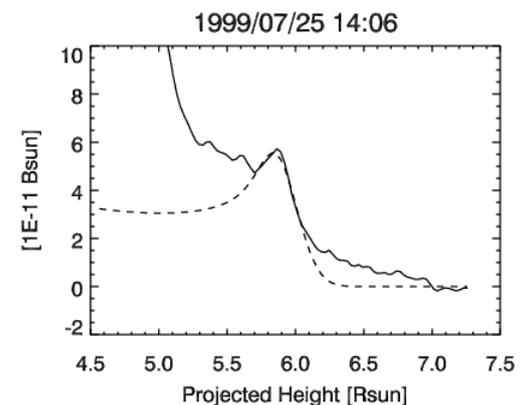
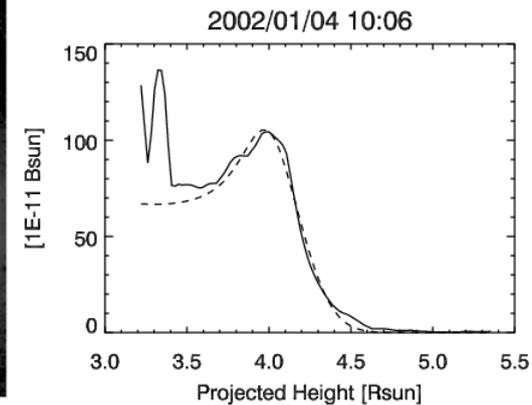
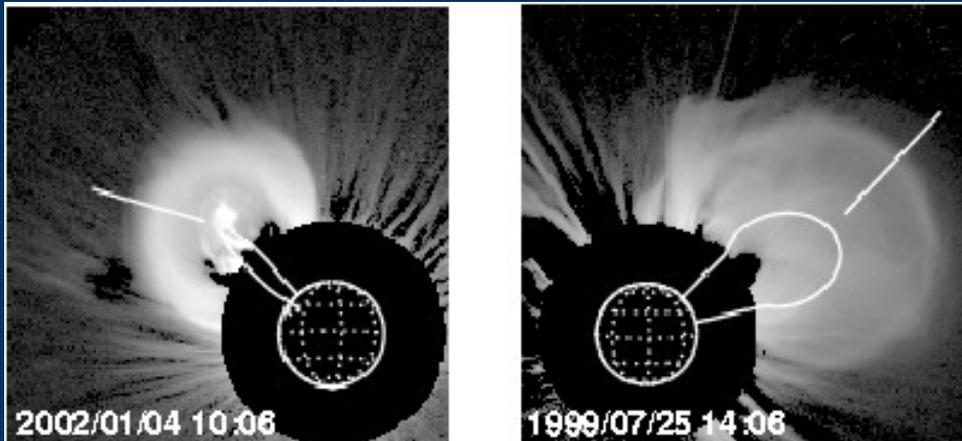

Cremades & Botmer, 2004, Thernisien, Howard & Vourlidas, 2006

Positioning the Model

Front or back ?

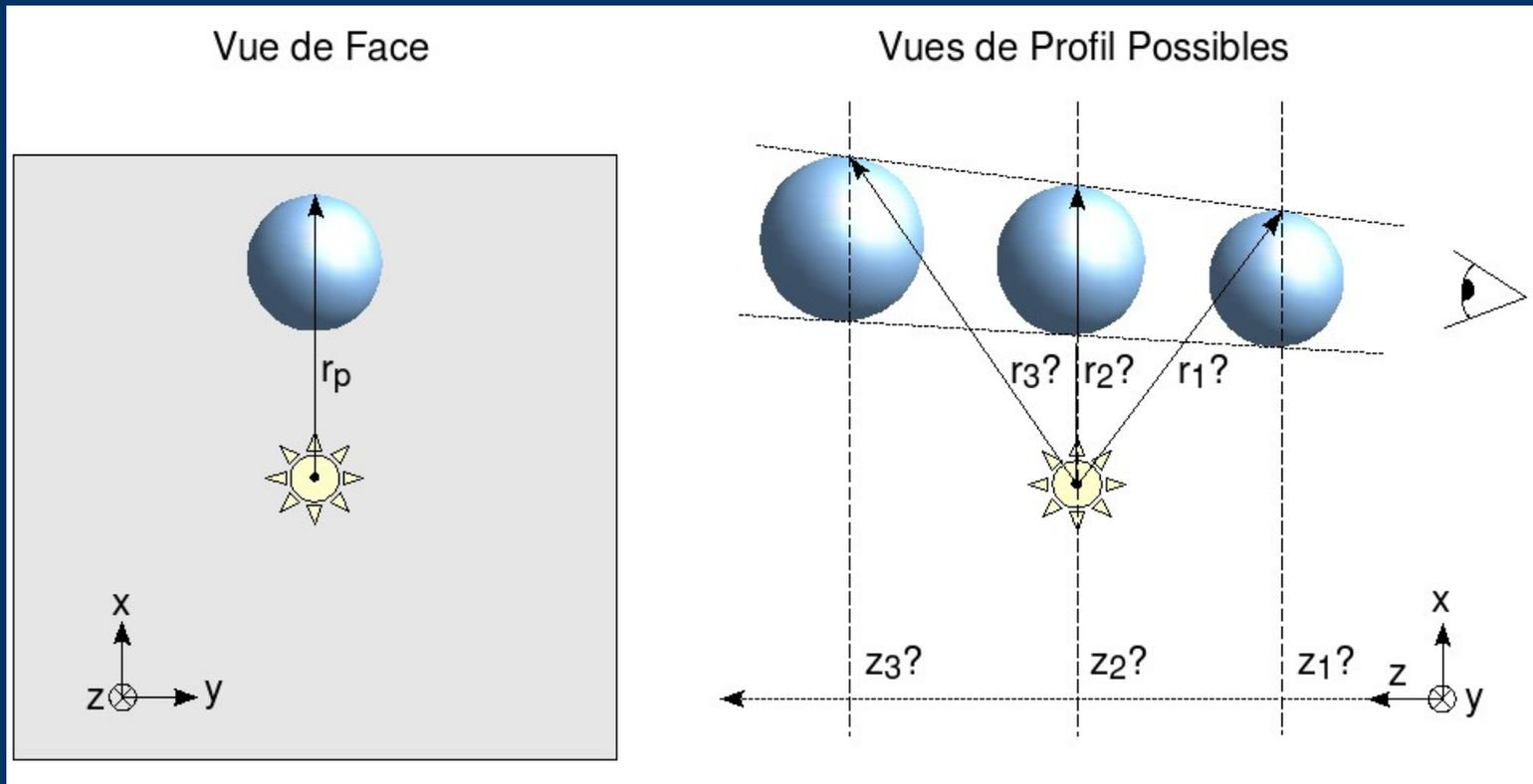

CME en tube de flux

Introduction

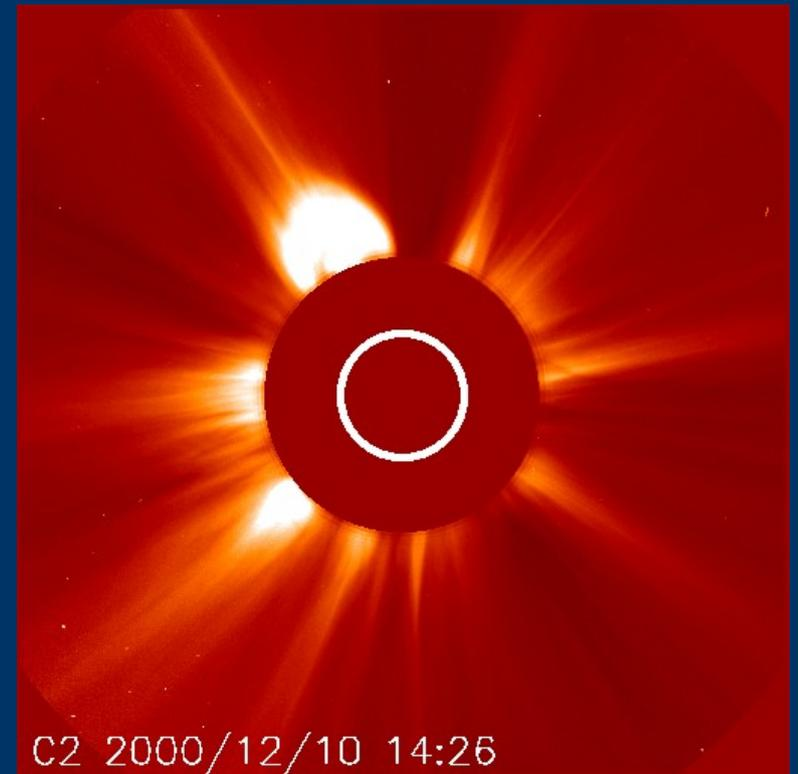
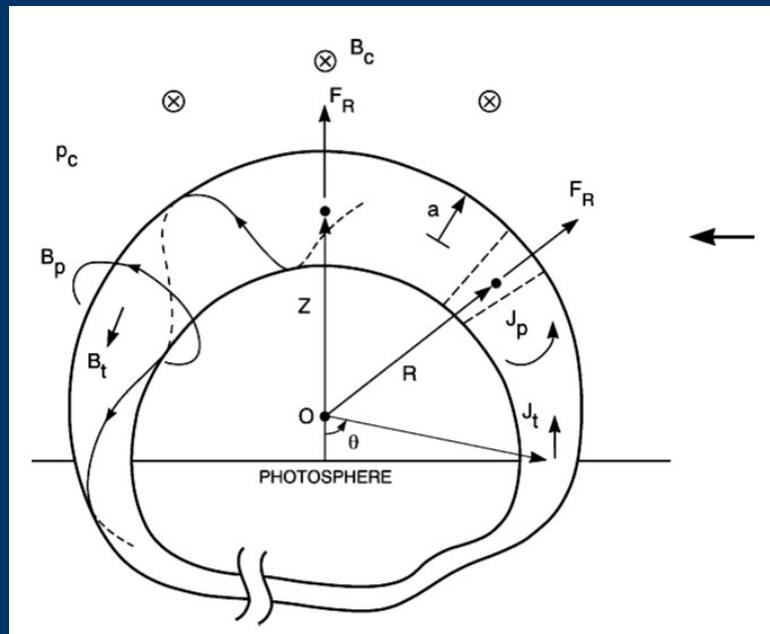
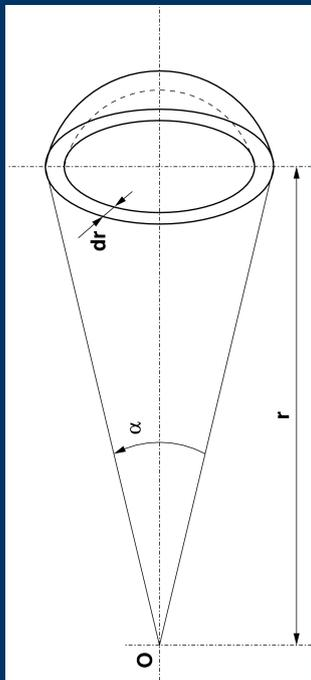

CME en tube de flux

Introduction

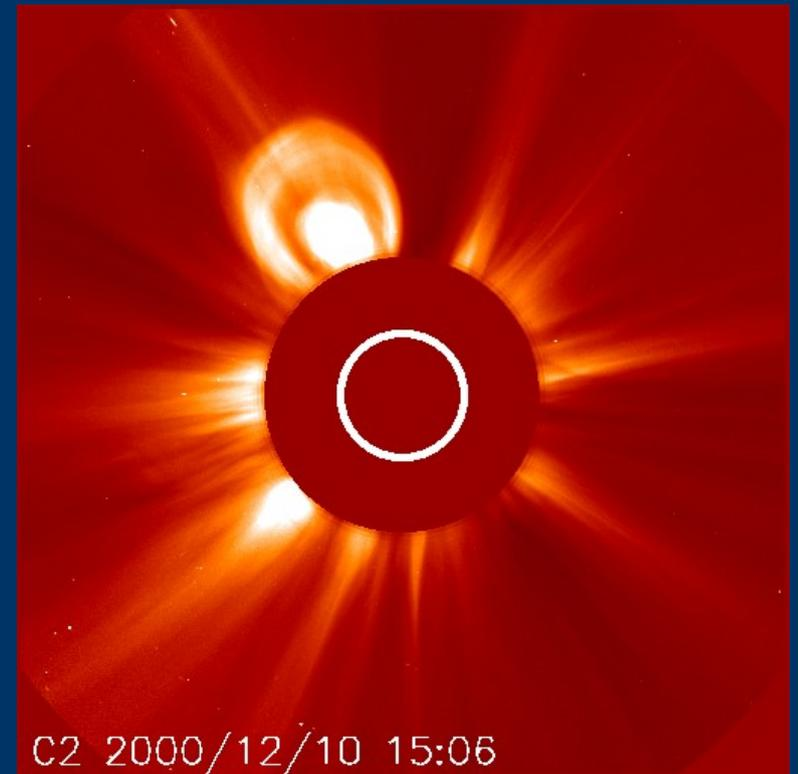
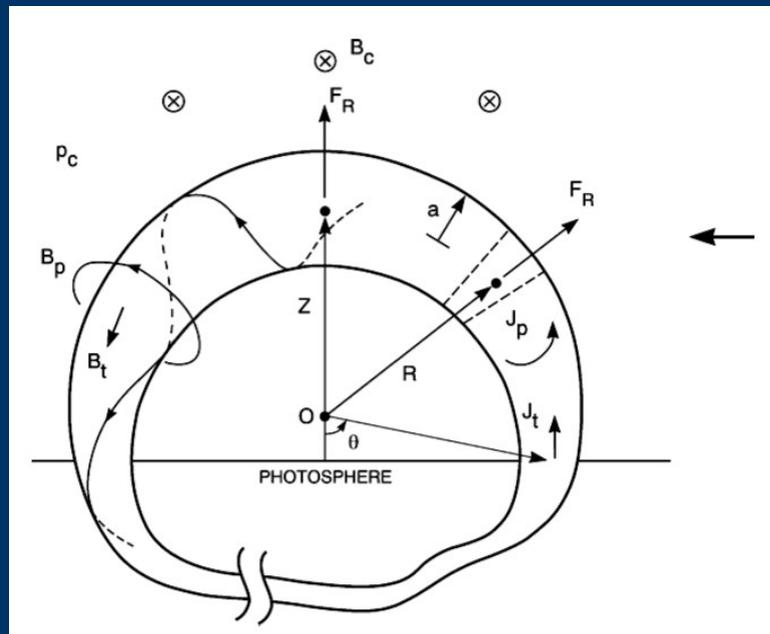
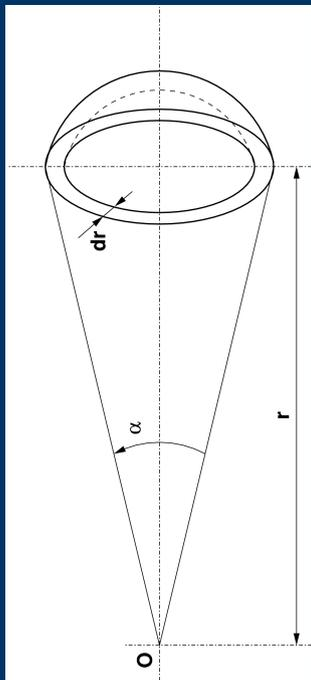

CME en tube de flux

Introduction

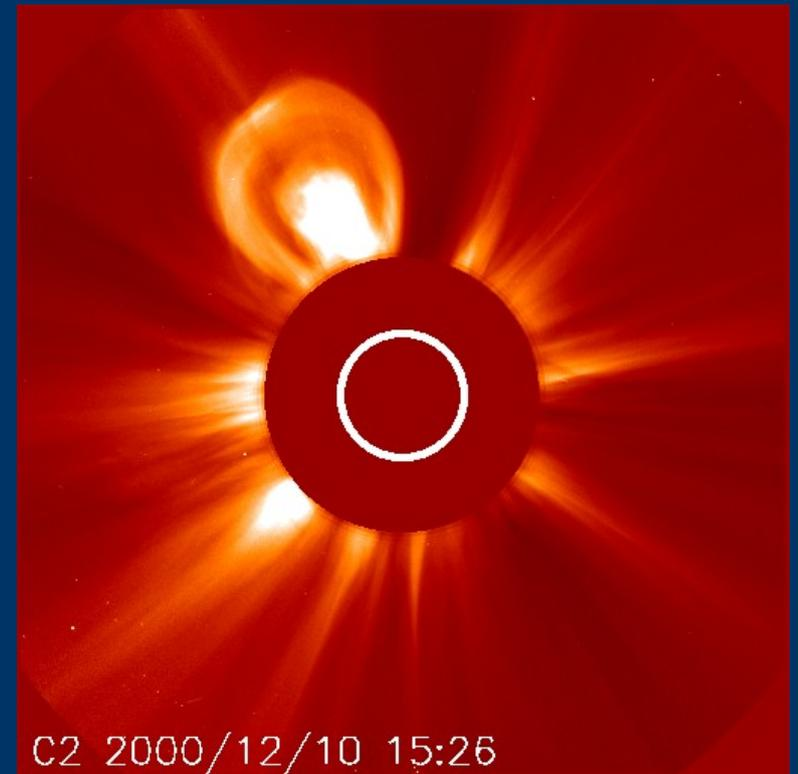
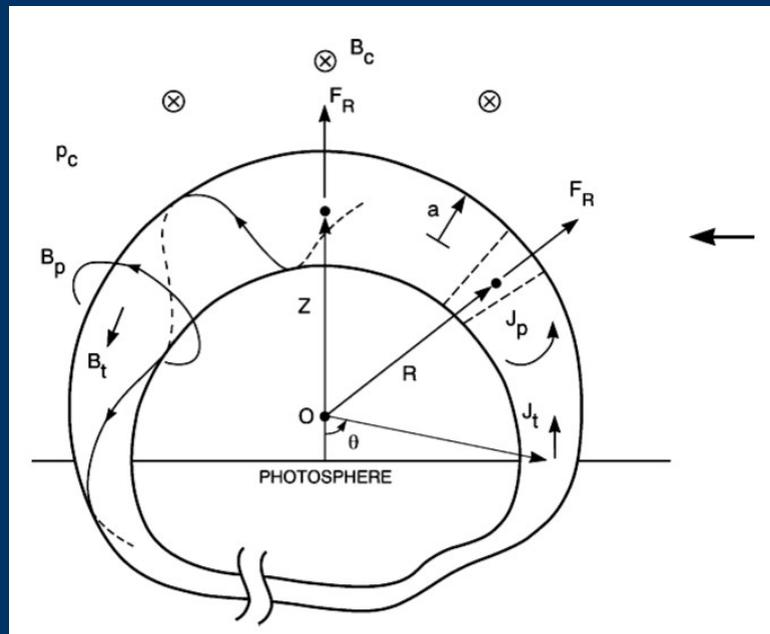
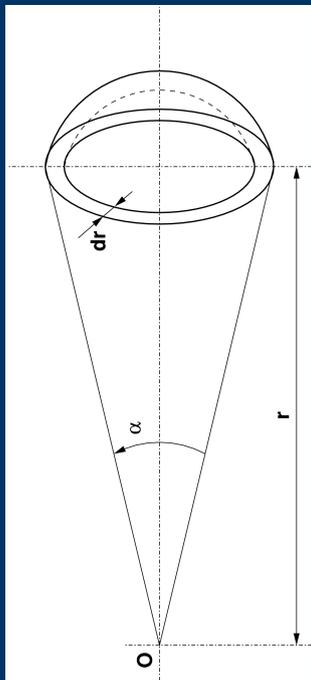

CME en tube de flux

Introduction

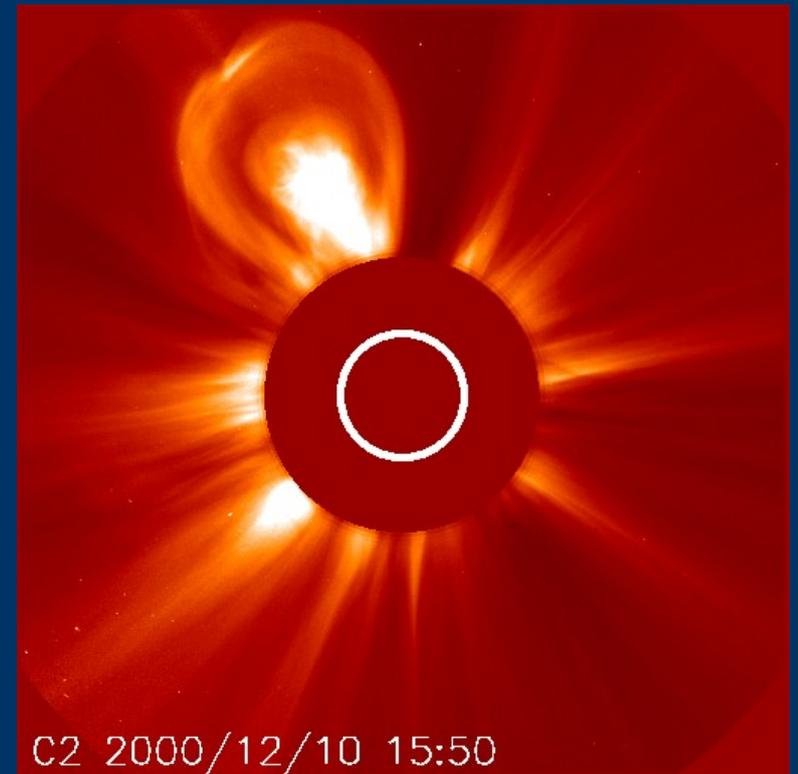
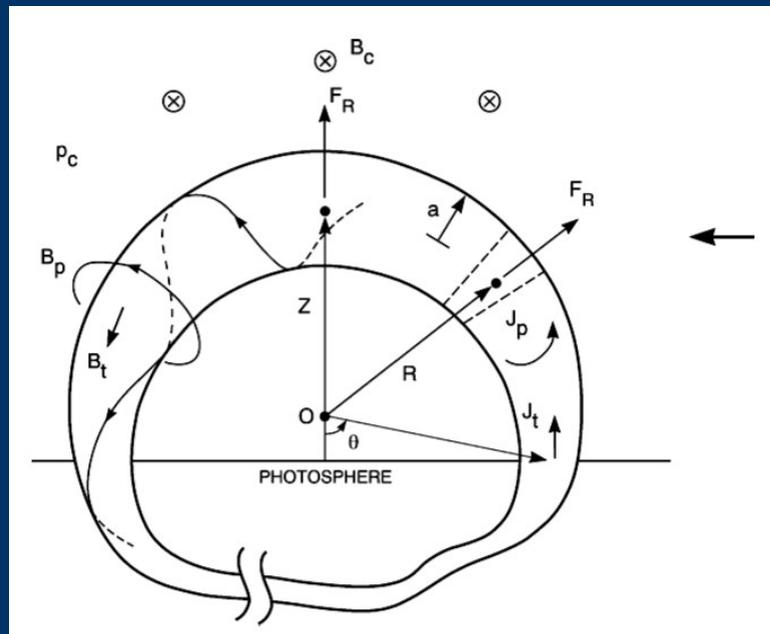
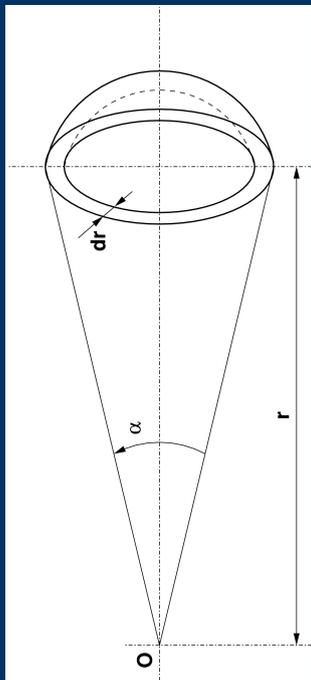

CME en tube de flux

Introduction

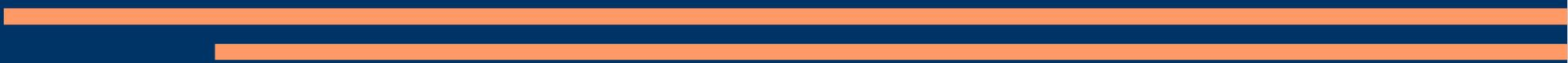
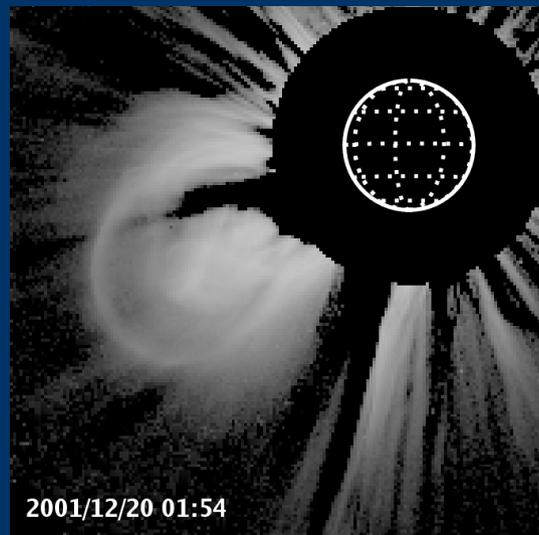
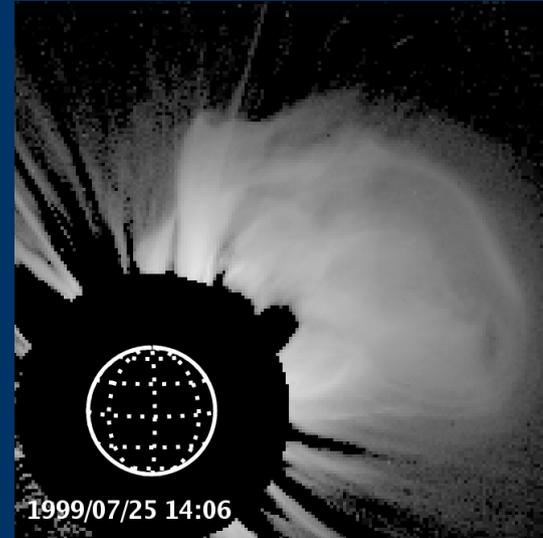
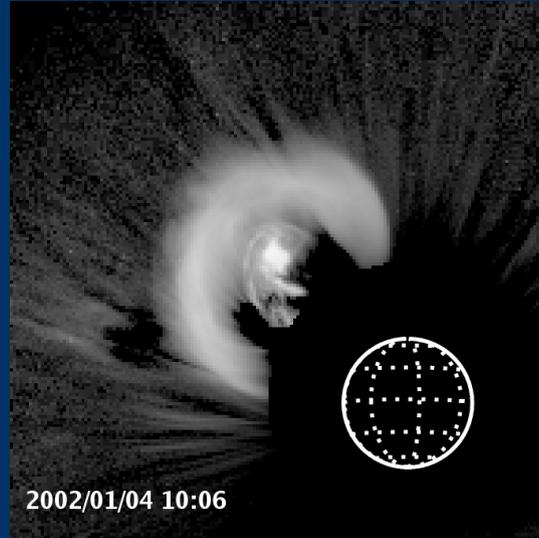

CME en tube de flux

Positionnement

- Indétermination sur la profondeur
 - On peut utiliser la position de la région source détectée avec EIT comme proxy. (Cremades & Bothmers, A&A, 2004)



Etude d'une CME avec STEREO-SECCHI

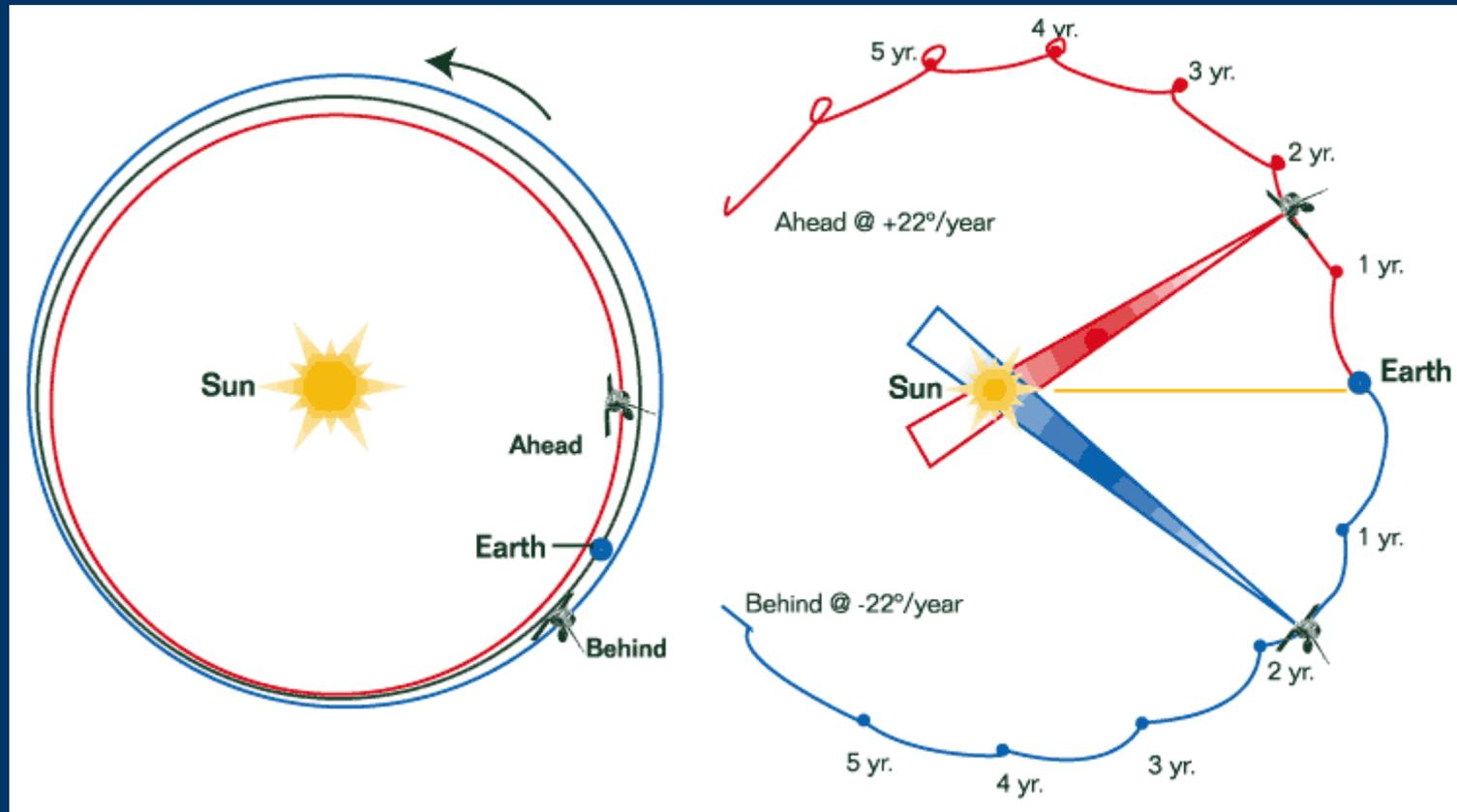

Etude d'une CME avec STEREO-SECCHI

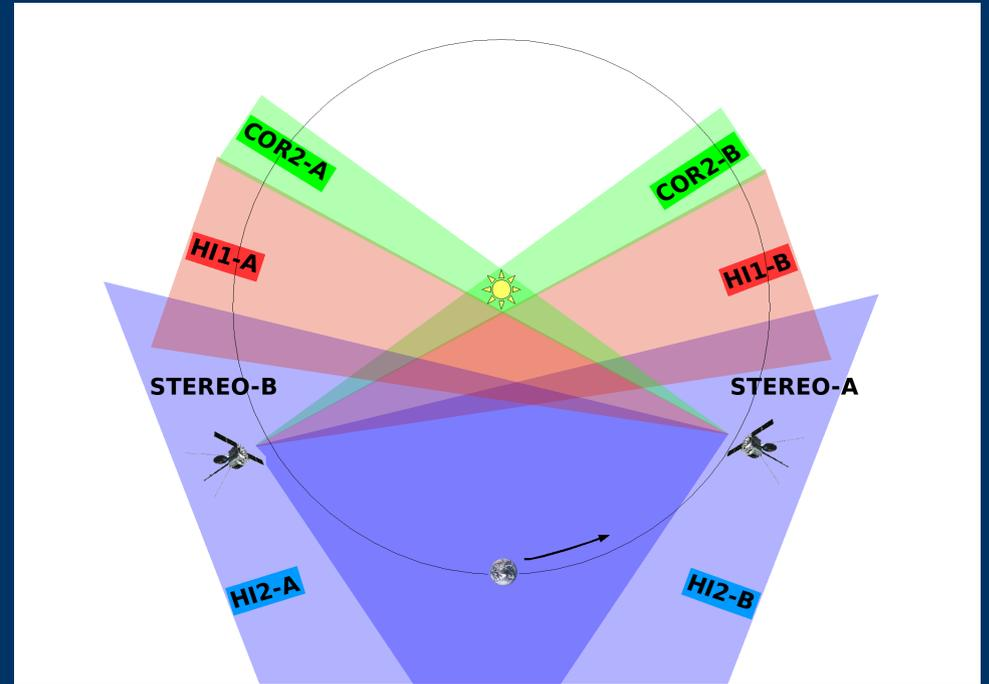
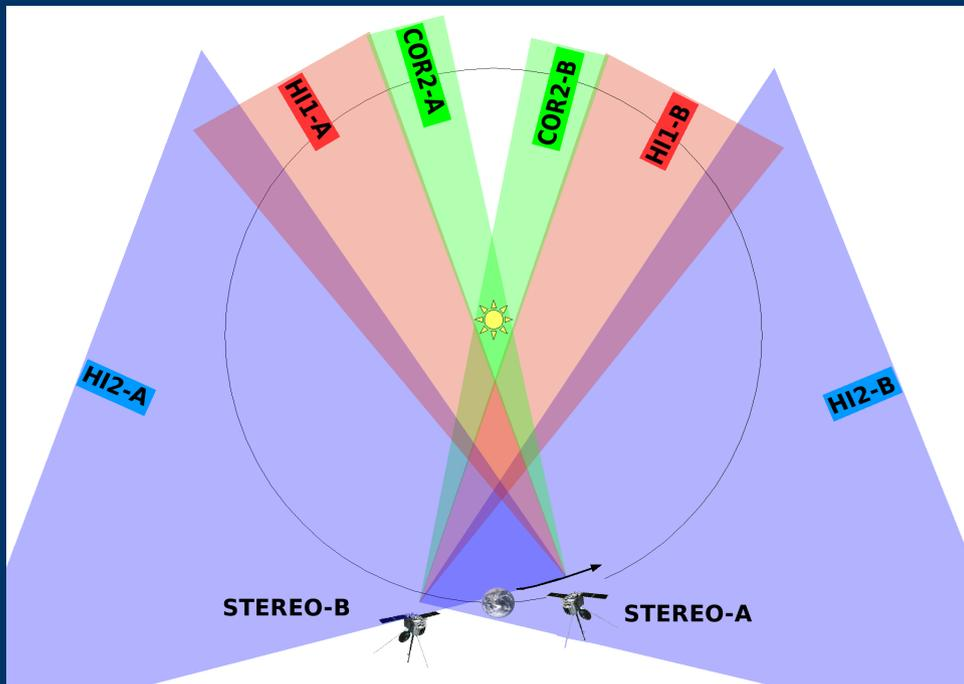

A Geometric Flux Rope Model

The Hollow Croissant Model

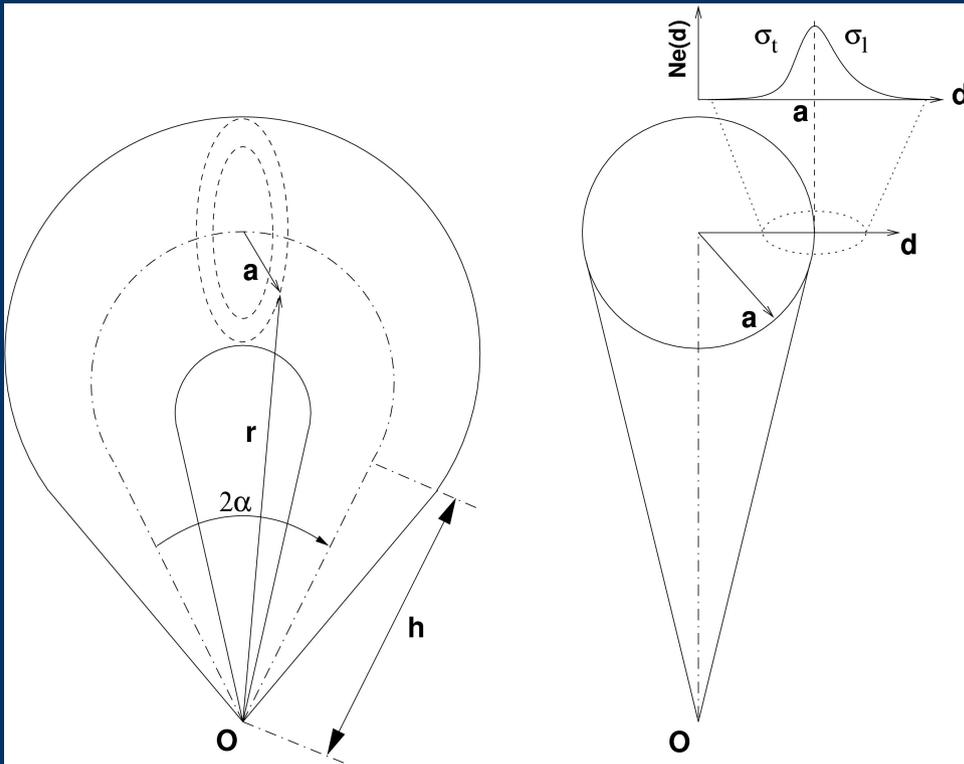

Self Similar : $a(r) = \kappa r$