

STEREO IMPACT

PROBLEM REPORT

PR-1012

IDPU LVPS

2004-07-15

PR Numbers: 1xxx=UCB, 2xxx=Caltech/JPL, 3xxx=UMd, 4xxx=GSFC/SEP, 5xxx=GSFC/Mag,
6xxx=CESR, 7xxx=Keil, 8xxx=ESTEC, 9xxx=MPAe

Assembly : IDPU	SubAssembly : LVPS
Component/Part Number:	Serial Number: FM1
Originator: David Curtis	Organization: U.C. Berkeley
Phone : 510-642-5998	Email : dwc@ssl.berkeley.edu

Failure Occurred During (Check one)

Functional test Qualification test S/C Integration Launch operations

Environment when failure occurred:

Ambient Vibration Shock Acoustic
 Thermal Vacuum Thermal-Vacuum EMI/EMC

Problem Description

The IDPU LVPS failed to take any current when 28V primary was powered on after integration with the flight MAG sensor. The unit had previously passed all of its subassembly tests with no issues. (see the next page for more details)

Analyses Performed to Determine Cause

A failure analysis was performed on the front end regulator - LT1766IGN, LDC 0150 and a JANTX1N440 zener diode and confirmed that the devices were electrically overstressed. (FRB held August 26, 2004, Reference F/A # Q40192FA). Probing on the board revealed a short between the internal 12V supply generated by the LT1766 (which runs on primary ground) and the secondary 12V supply. This was caused by a layout error that can be easily fixed by cutting one trace. The ETU, which has several hundred hours of trouble-free operation, does not have this layout error. When the primary and secondary grounds are not connected together (as is the case in board-level tests) this has no significant effect. But when the grounds are connected, as is usually the case at IDPU-level tests, the primary and secondary supplies compete. The output impedance of the secondary supply is large enough to take up the difference without stressing anything when the supplies are stable. But during turn-on the effect of the supply in-rush limiter with this connection between supplies and grounds causes a negative transient on the internal +12V supply with respect to internal ground. This negative transient can stress the LT1766, and potentially other parts in the supply (there is no negative transients on the secondary supplies, so no concern about the rest of the IDPU). A partial power converter was built up to validate this analysis. After a few turn-on attempts the LT1766 failed exactly like the flight unit, presumably due to these negative transients. Repeated power cycles without the short between 12V supplies showed no problem.

Corrective Action/ Resolution

Rework Repair Use As Is Scrap
1. Cut the trace on the PWB due to the layout error. This fix was completed on both FM1 and FM2.
2. The circuit was analyzed for any stressed parts. The parts identified as stressed (see repair sequence on the last page) were replaced in addition to the LT1766IGN and zener diode JANTX1N440. This effort was completed only on FM1. (FM2 had not seen any power yet)

Date Action Taken: 8/25/2004 **Retest Results:** Success (subassembly level tests and higher)

Corrective Action Required/Performed on other Units Serial Number(s): FM2

Closure Approvals

Subsystem Lead:	_____	Date: _____
IMPACT Project Manager:	_____	Date: _____
IMPACT QA:	_____	Date: _____
NASA IMPACT Instrument Manager:	_____	Date: _____

STEREO IMPACT

PROBLEM REPORT

PR-1012

IDPU LVPS

2004-07-15

The IDPU LVPS passed its subassembly test with no issues. It was then integrated with the ETU IDPU and again worked fine. Finally it was assembled with the FM1 IDPU and again worked fine (using the ETU MAG sensor). The unit was then placed in an ESD bag and walked across the street to the high bay where it was integrated with the flight MAG sensor then in the thermal vac chamber with the FM1 IMPACT boom (along with the associated GSE). The IDPU failed to take any current when 28V primary was powered on. It was then disconnected and returned to the bench where it had worked and it still failed to function.

The IDPU LVPS was removed from the IDPU and returned for diagnostics to the power converter group. It was determined that the LT1766 front-end regulator had failed (open); the normal signal levels were on its inputs, but there was no output. The board was inspected for anything that might have stressed the supply, such as a short to chassis or a loose wire. Nothing was identified, but we did decide to add kapton tape to areas of the inside of the chassis that come close to components. The chassis wiring was verified to be correct (board level tests bypass that wiring). The FM1 IDPU electronics were re-mated with the ETU LVPS, which worked fine. That was then connected to the FM1 boom/MAG thermal vac test setup and worked fine.

The LT1766 (U1) was removed from the supply. The technician noted that some of the pads were soldered to the part but loose from the board prior to starting to remove the part. The pads came off with the part. All of the loose pads were no-connects. The remaining pads were still well attached to the board.

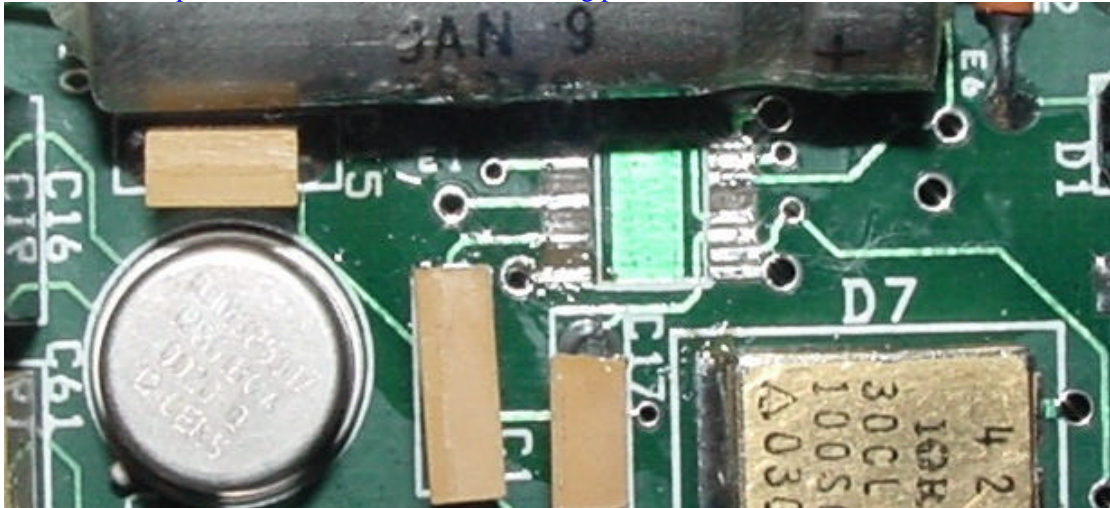

The board was inspected by QA and a repair procedure was written up and implemented to install a new LT1766 to the board (pins with no pads were attached to board with Scotchweld 1836.).

In subsequent testing it was found that a zener diode had also failed (D6). This zener is across the input of the LT1766 to protect against over voltage into the part. It had failed shorted. It was not failed before the LT1766 was replaced (there was no short), but may have been damaged by the same event that killed the LT1766 and then failed later. The zener was replaced.

The reworked board now seems to work fine. It passed the board-level functional test. The removed parts are available for failure analysis; evidence of ESD damage should be looked for.

STEREO IMPACT

PROBLEM REPORT

PR-1012

IDPU LVPS

2004-07-15

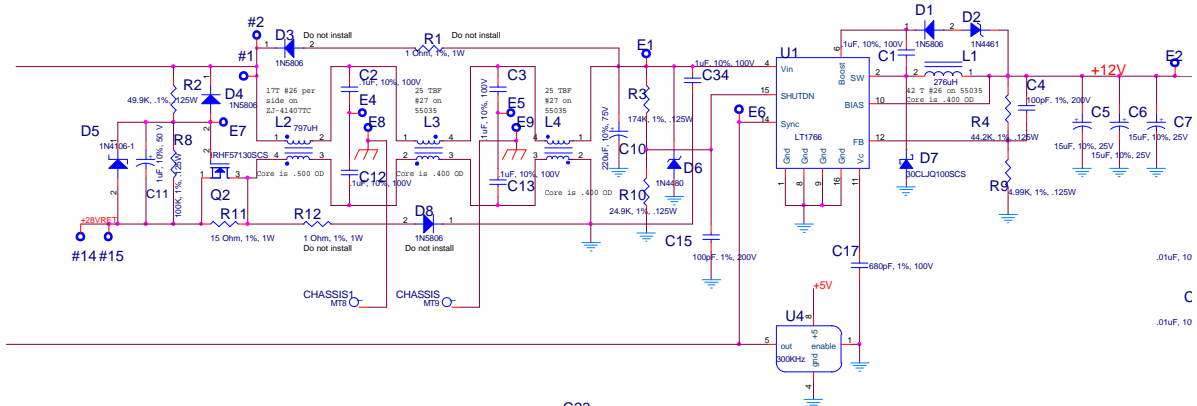

2004-08-19

Preliminary results from failure analysis indicates electrical over-stress caused the failure of the LT1766.

After a few hours of system-level tests the supply failed again in the exact same way. In each case the failure occurred when the supply was switched on in such a manner that the in-rush current was not externally limited.

Probing on the board revealed a short between the internal 12V supply generated by the LT1766 (which runs on primary ground) and the secondary 12V supply. This was caused by a layout error that can be easily fixed by cutting one trace. The ETU, which has several hundred hours of trouble-free operation, does not have this layout error. When the primary and secondary grounds are not connected together (as is the case in board-level tests) this has no significant effect. But when the grounds are connected, as is usually the case at IDPU-level tests, the primary and secondary supplies compete. The output impedance of the secondary supply is large enough to take up the difference without stressing anything when the supplies are stable. But during turn-on the effect of the supply in-rush limiter with this connection between supplies and grounds causes a negative transient on the internal +12V supply with respect to internal ground. This negative transient can stress the LT1766, and potentially other parts in the supply (there is no negative transients on the secondary supplies, so no concern about the rest of the IDPU).

A partial power converter was built up to validate this analysis. It was demonstrated that the supply behaves well when there is not the incorrect connection between supplies, but when they are connected we see a $\sim 1V$ transient (with respect to internal ground) for $\sim 10\mu s$ on the SW output of the LT1766 (data sheet says this should not go below $-0.8V$). Also the 12V supply has a $\sim 8V$ transient (with respect to internal ground) for $\sim 100\mu s$, which shows up on the BIAS signal of the LT1766. After a few turn-on attempts the LT1766 failed exactly like the flight unit, presumably due to these negative transients. Repeated power cycles without the short between 12V supplies showed no problem.

STEREO IMPACT

PROBLEM REPORT

PR-1012

IDPU LVPS

2004-07-15

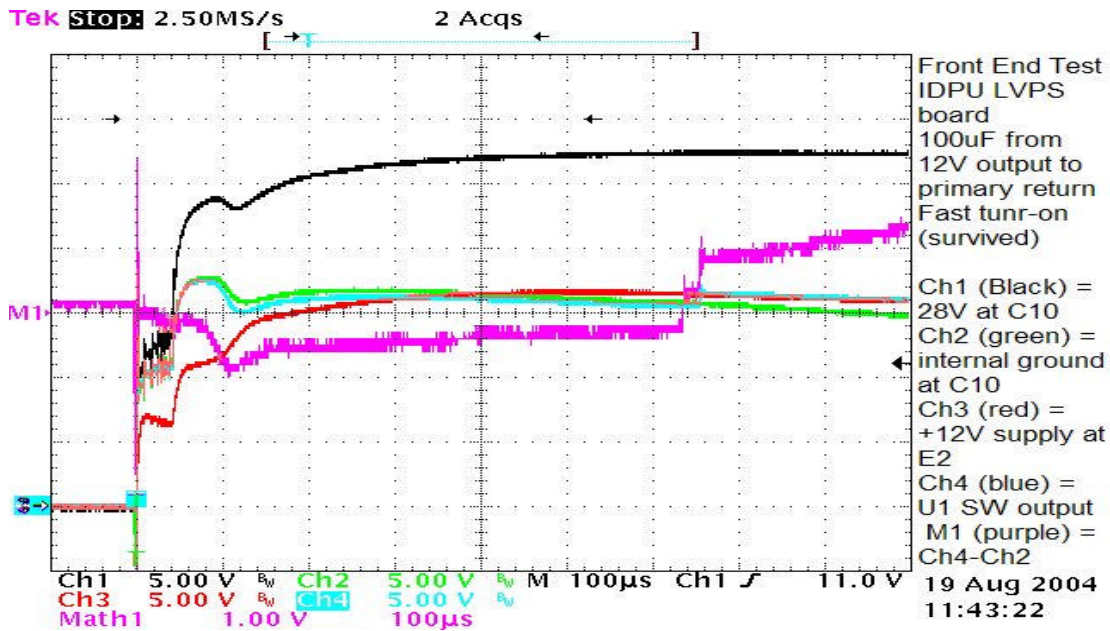

Repair Sequence:

1. First replacement of the LTC1766 (U1) in a work order dated 7/19/2004 (with the loose pads problem).
2. A work order dated 7/20/2004 called for the replacement of the zener diode, D6, JANTXV1N4480, LDC H9829.
3. Finally in a work order dated 8/25/2004 the offending trace was cut and the stressed parts were replaced, including:
 - a. U1, LT1766, LDC 0150
 - b. U2, 5962-9320901MPA, LDC 9846A
 - c. U3, JM38510/12801BGA, LDC 034513
 - d. U8, U14 5962F9951102VXC, LDC 9931
 - e. D6, JANTXV1N4480, LDC 9829
 - f. C5, C6, C7, C8, C44, C50, CWR06KC156KP, LDC 0149V
4. In a separate work order dated 8/25/2004 the FM2 supply had the offending trace cut. It had not yet been powered and so had not been stressed.

To: Vinod_Patel
From: Antonio Reyes <areyes@pop400.gsfc.nasa.gov>
Subject: FRB on LT1766IGN, LDC 0150
Attendees: Lillian Reichenthal, Antonio Reyes, Dave Curtis (Telecon)

References: IMPACT PR-1012-IDPU-FM1
Code 562 F/A Report # Q40192FA

On August 26, 2004, at 1:30 PM, Bldg 6/S126, a failure review (FRB) was held in Lil's office to discuss the failure (PR-1012) of a 1.5-Ampere pick step-down switching regulator, used in the STEREO/IMPACT-IDPU FM1. The LVPS failure occurred during functional box level testing.

Problem Description: The IDPU LVPS passed its subassembly test with no issues. It was then integrated with the ETU IDPU and again worked fine. Finally it was assembled with the FM1 IDPU and again worked fine (using the ETU MAG sensor). The unit was then placed in an ESD bag and walked across the street to the high bay where it was integrated with the flight MAG sensor then in the Thermal-Vac chamber with the FM1 IMPACT boom (along with the associated GSE). The IDPU failed to take any current when 28V primary was powered on. It was then disconnected and returned to the bench where it had worked and it still failed to function.

The failed device (U1, manufactured by Linear Technology, P/N LT1766IGN, LDC 0150) was removed from the supply and sent to Code 562 Analysis Lab for F/A. Electrical testing confirmed the failure. Analysis found that the diode and the microcircuit had both been damaged by electrical overstress (EOS). No intrinsic defects were found in the device.

The LTC1766 and a zener diode were replaced and the supply was functioning properly again. However, after a few hours of system-level tests the supply failed again in the exact same way. In each case the failure occurred when the supply was switched on in such a manner that the in-rush current was not externally limited. Probing on the board revealed a short (layout error) between the internal 12V supply generated by the LT1766 (which runs on primary ground) and the secondary 12V supply. The ETU, which has several hundred hours of trouble-free operation, does not have this layout error. When the primary and secondary grounds are not connected together (as is the case in board-level tests) this has no significant effect. But when the grounds are connected, as is usually the case at IDPU-level tests, the primary and secondary supplies compete. The output impedance of the secondary supply is large enough to take up the difference without stressing anything when the supplies are stable. But during turn-on the effect of the supply in-rush limiter with this connection between supplies and grounds causes a negative transient on the internal +12V supply with respect to internal ground. This negative transient can stress the LT1766, and potentially other parts in the supply (there is no negative transients on the secondary supplies, so no concern about the rest of the IDPU). A partial power converter was built up to validate this analysis. It was demonstrated that the supply behaves well when there is not the incorrect connection between supplies, but when they are connected we see a ~ -1V transient (with respect to internal ground) for ~10us on the SW output of the LT1766 (data sheet says this should not go below -0.8V). Also the 12V supply has a ~-8V transient (with respect to internal ground) for ~100us, which shows up on the BIAS signal of the LT1766. After a few turn-on attempts the LT1766 failed exactly like the flight unit, presumably due to these negative transients. Repeated power cycles without the short between 12V supplies showed no problem.

Disposition: The cause of failure has been attributed to a layout error that can be easily fixed by cutting one trace on the PWB.

Regards,

Antonio Reyes
STEREO Parts Engineer

X65927

GODDARD SPACE FLIGHT CENTER

Failure Analysis Report

"The information contained herein is presented for guidance of employees of the Goddard Space Flight Center. It may be altered, revised, or rescinded due to subsequent developments or additional test results. These changes could be communicated internally by other Goddard publications. Notice is hereby given that this document is distributed outside of Goddard as a courtesy only to other government agencies and contractors and is understood to be only advisory in nature. Neither the United States Government nor any person acting on behalf of the United States Government assumes any liability resulting from the use of the information contained herein."

Project:	STEREO	Part Type:	Microcircuit/Diode
Subsystem:	IMPACT-IDPU LVPS	Manufacturer:	Linear Technology
Date:	20 August 2004	Part Number:	LT1766IGN, 1N4480
Investigator:	F. Felt 286-9634	Date Code:	0150
Requestor:	A. Reyes 286-5927		

Background

The STEREO IDPU (FM1) failed during first power on after integration with the flight MAG sensor and the IMPACT boom. However, prior to integration, this unit had successfully passed subassembly testing and integration to the FM1 IDPU Assembly.

Subsequent trouble-shooting isolated two failing parts in the IDPU: an LT1766 front-end regulator, and a JANTX1N4480 Zener diode. These parts were replaced, and the IDPU unit was reported as functioning successfully.

The failing parts were forwarded to the NASA GSFC Failure Analysis Laboratory for examination.

Part Description

The LT1766IGN is a high-voltage, 1.5-ampere peak switching current, 200kHz step-down switching regulator. The device has a low effective supply current of 2.5mA, and a shutdown current of 25 μ A. It features a 5-volt fixed output and a 1.2-volt feedback reference voltage. The package is a 16-pin SSOP. The LT1766IGN is manufactured by Linear Technologies.

The 1N4480 diode is a 1.5-watt, 43-volt zener diode, hermetically packaged in a glass-body with axial leads. It has an operating temperature

range of -65°C to $+175^{\circ}\text{C}$. It has a maximum rating of 33 mA in continuous operation, and 480 mA in surge.

Analysis and Results -- Microcircuit

The microcircuit was optically inspected. No external damage was found on the package body. However, Pin 3, which was reported as not connected when removed from the board, appeared to have foreign material on the bottom of the lead. Pin 7, also reported as not connected, appeared to have a clump of solder on its end, and exhibited both a melted and a fractured surface. SEM and EDS were conducted. Contamination on Pin 3 contained carbon, oxygen, fluorine, and bromine, suggesting solder flux residue. Pin 13 also had some contamination.

Pin-to-pin curve tracer testing was performed on the failing microcircuit, and on a control part. Comparison of the results between the two parts showed several differences. Notably, the failed part was electrically open between Pins 4, 11, and 12. These three pins also exhibited opens with several other pins. However, the primary intersection failure occurred between these three pins.

Radiography was conducted. No anomalies were noted. X-rays revealed that the wires

and die were oriented normally inside the plastic package.

The part was decapsulated and inspected under high-power optical examination. Baked-on encapsulant was found in an area slightly off-center from the middle of the die, where the underlying traces had 'cooked' the plastic material into an acid-resistant state. The anomaly was photographed and examined under the SEM. Sulfuric acid was used to partially etch the attached encapsulant. The part was then re-examined. At this point, melted and missing metal at multiple locations in the affected area was identified and photographed. This evidence confirmed the failure as being due to electrical overstress (EOS).

Analysis and Results -- Diode

The diode was optically inspected and photo-documented. Except for the fact that one lead had been trimmed close to the glass body during removal from the board, no external anomalies were noted. The diode package was a painted glass body, with axial leads.

Curve tracer examination was conducted. The diode was found to have a low-resistance short, with a slope of 1.84 ohms (including lead resistance).

The diode was potted and cross-sectioned. A crack was found in the glass body of the diode at Level 0, suggesting possible thermal stress. Subsequent cross sections levels were uninteresting until, at Level 6, a void was found approximately in the center of the silicon die. Optical inspection under a dark-field microscope showed that the

metallurgical alloy normally present at the bonding interface had dispersed throughout an egg-shaped volume, which spanned the die from anode and cathode, creating a shorting path.

This damage was also assessed as being due to electrical overstress (EOS).

Second Failure

Concurrent with the failure analysis, a second failure occurred on the FM1 IDPU LVPS at the University of California Berkeley. After diagnosis and analysis it was determined that a layout error existed on the power converter board coupling the primary and secondary sides of the power supply. In the opinion of Project personnel, when grounds were connected (as they would be in flight), turn-on transients were placing excessive strain on the front end of the power converter.

Conclusion

The failure was electrically confirmed. Analysis found that the diode and the microcircuit had both been damaged by electrical overstress (EOS). No intrinsic defects were found in either device. The circuit schematic was not provided for analysis, however, a layout error in the board is suspected by Project personnel as the root cause of failure.

Several leads were found disconnected when the microcircuit was removed from the circuit board.

GODDARD SPACE FLIGHT CENTER
Part Type Microcircuit
Manufacturer Linear Technology

Part Number LT1766IGN
Date Code 0150

Appended Photographs:

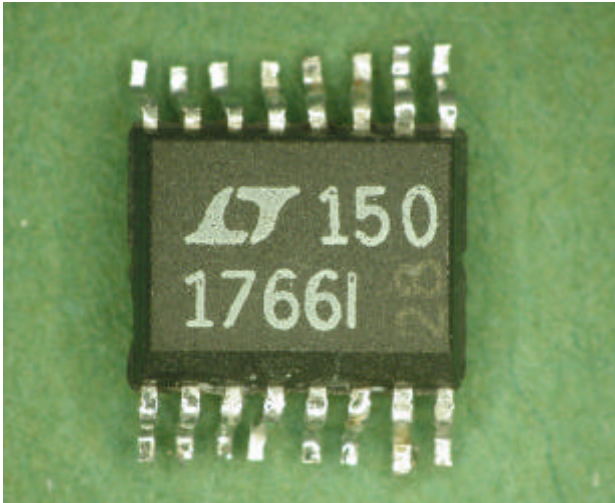

Figure 1. A top view of the Linear Technologies LT1766IGN, 16-pin microcircuit.

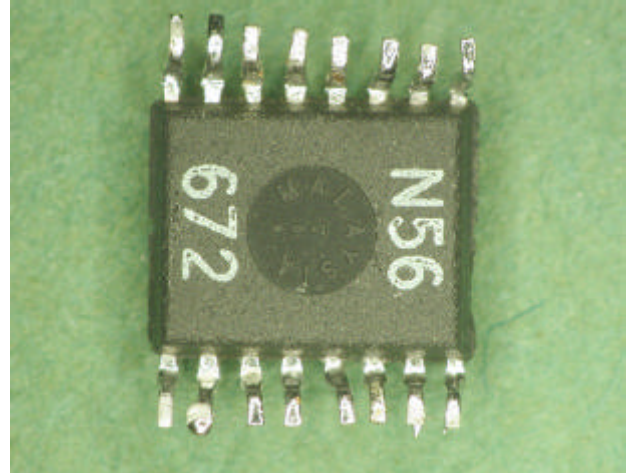

Figure 2. A bottom view of the device.

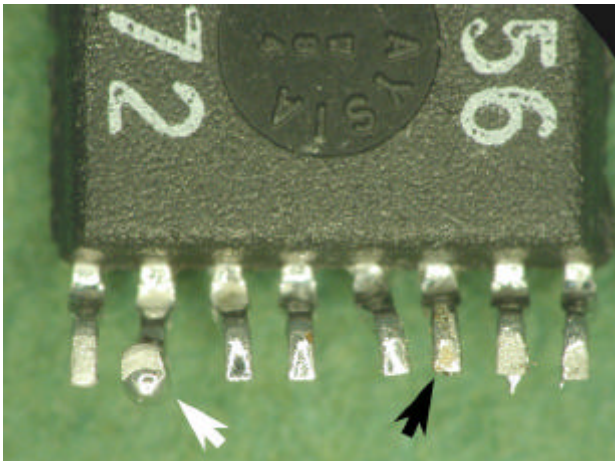

Figure 3. The white arrow points to Pin 7, which has a blob of solder. The black arrow points to contamination found on Pin 3. EDS analysis of this material showed high concentrations of carbon, oxygen, fluorine, and bromine—constituents of solder flux. Note that Pins 1, 2, 3, 7, and 8 appear rough.

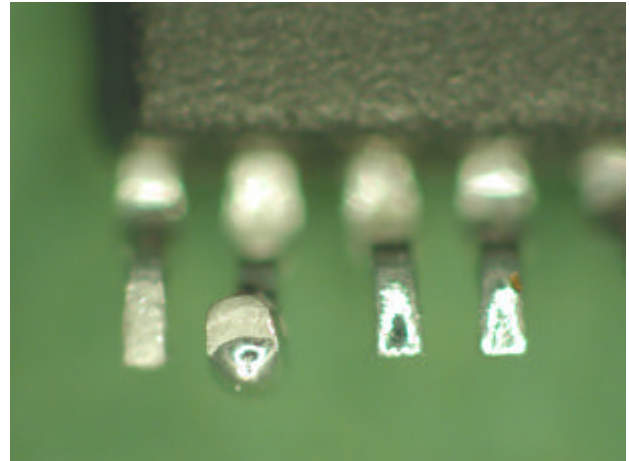

Figure 4. The bottom of Pin 7 exhibits both a melted and a fractured surface.

GODDARD SPACE FLIGHT CENTER
Part Type Microcircuit
Manufacturer Linear Technology

Part Number LT1766IGN
Date Code 0150

Appended Photographs:



Figure 5. A side view of the 1N4480 diode. One lead was clipped close to the body during removal from the board. Curve tracer testing found the device was shorted.



Figure 6. This end of the diode view shows a glass body under the paint.

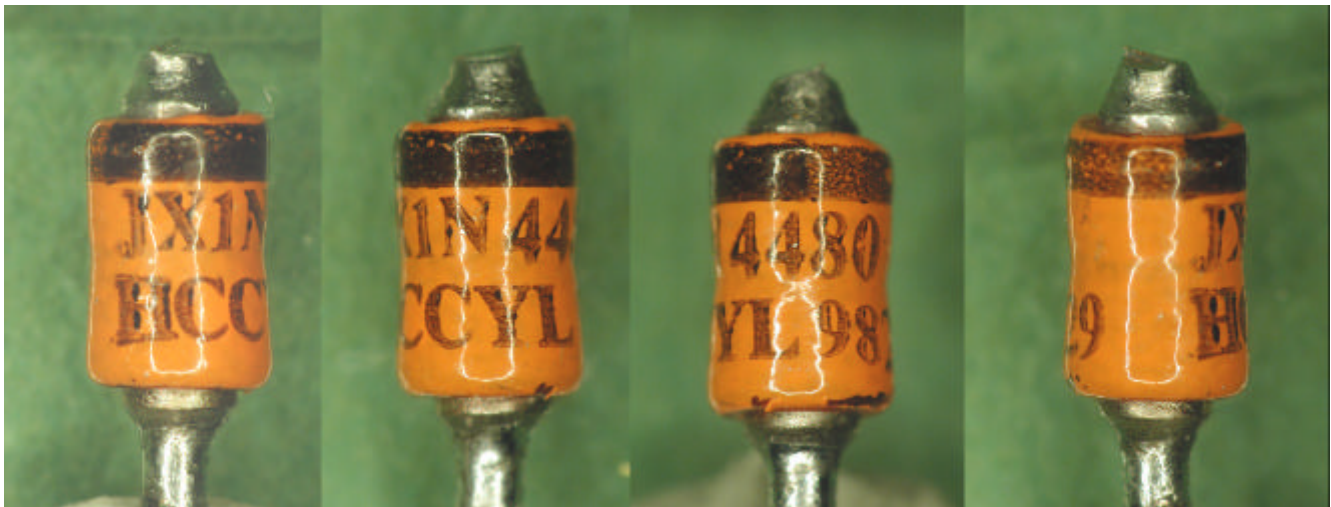

Figure 7. A sequence of rotated views documents the part markings: JX1N4480 HCCYL 9829.

Appended Photographs:



Figure 9. A tilt SEM view of Pin 7 reveals a large glop of solder on the end of Pin 7, the bottom of which appears to have two surfaces as seen in the image at right.

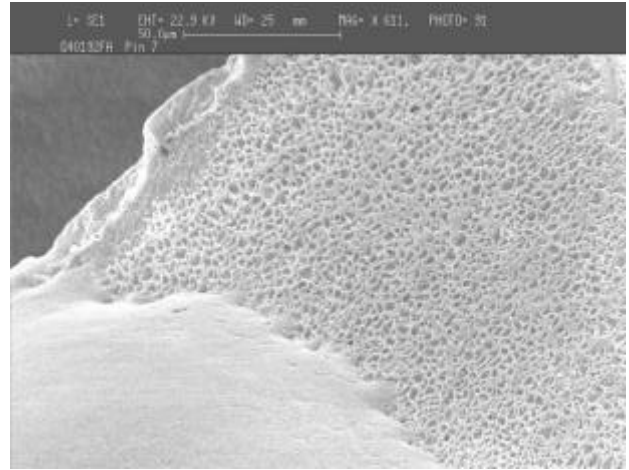

Figure 10. The bottom of the Pin 7 shows evidence of melted solder over a possible fracture surface.

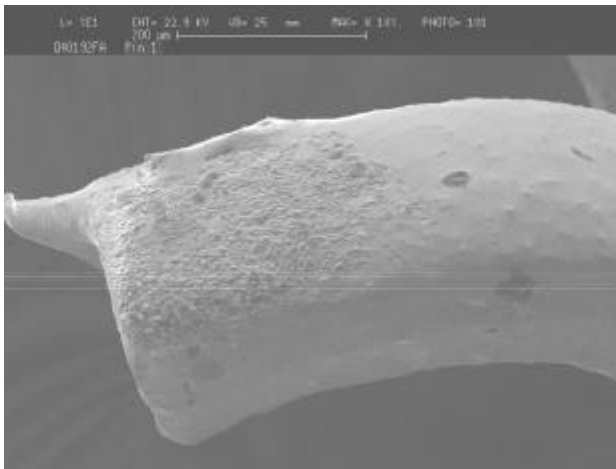

Figure 11. Several of the pins on one side of the package, such as Pin 1 shown above, had questionable contact surfaces—with neither clear evidence of melting from de-solder, nor evidence of fracture. Three pins on this side, Pins 3, 5 and 7, were reported as disconnected when the part was removed. Pin 13 was reported as disconnected on the other side of the package.

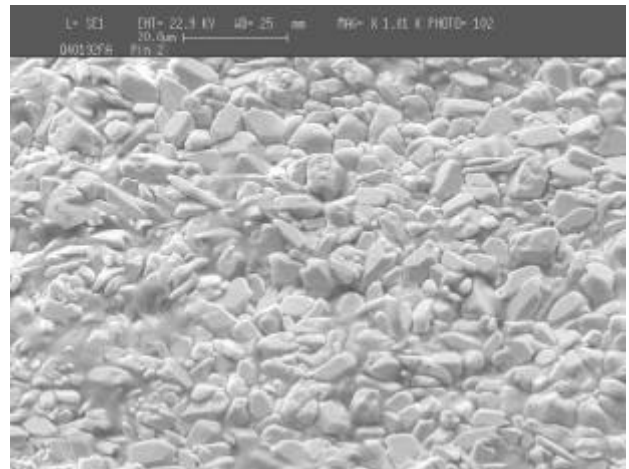

Figure 12. A close-up of the contact surface of Pin 2 shows a rubble-like topography, and was possibly never connected.

GODDARD SPACE FLIGHT CENTER
Part Type Microcircuit
Manufacturer Linear Technology

Part Number LT1766IGN
Date Code 0150

Appended Photographs:

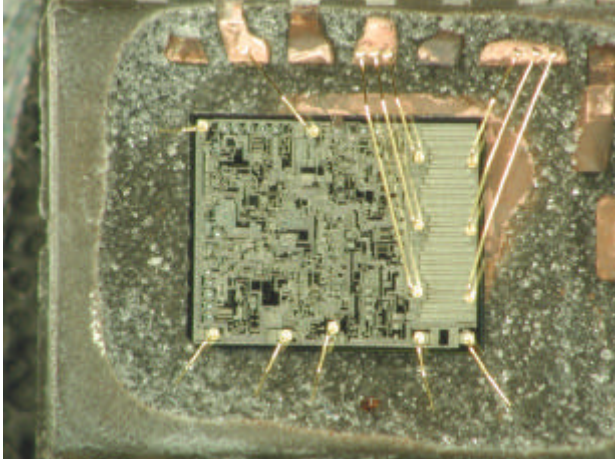

Figure 13. A view of the die and wire bonds, taken after opening. Heat-hardened encapsulant was found left of the die center in the above image (see Figure 14).

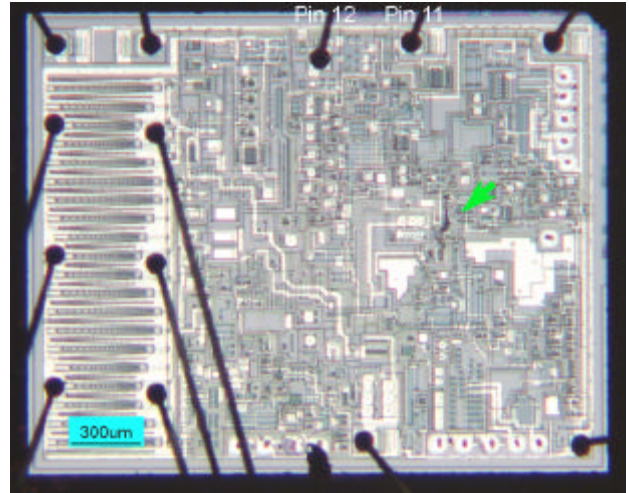

Figure 14. The image shows the overall die. The green arrow points to a location damaged by electrical overstress. Pins 11 and 12 are labeled.

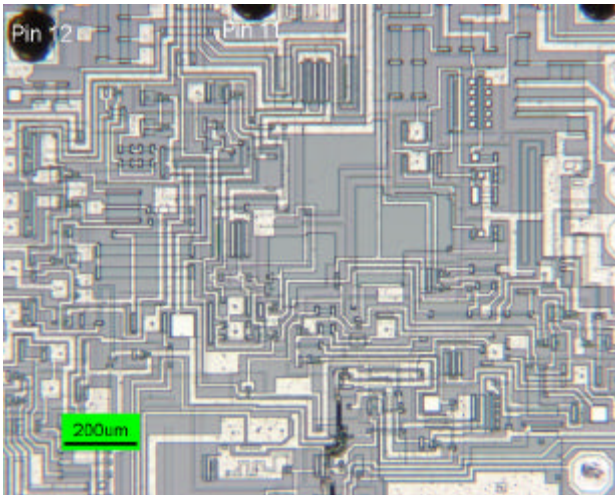

Figure 15. A higher magnification view of the die, showing damage at bottom center. Pins 11 and 12 are seen at top; left of center, and far left, respectively.

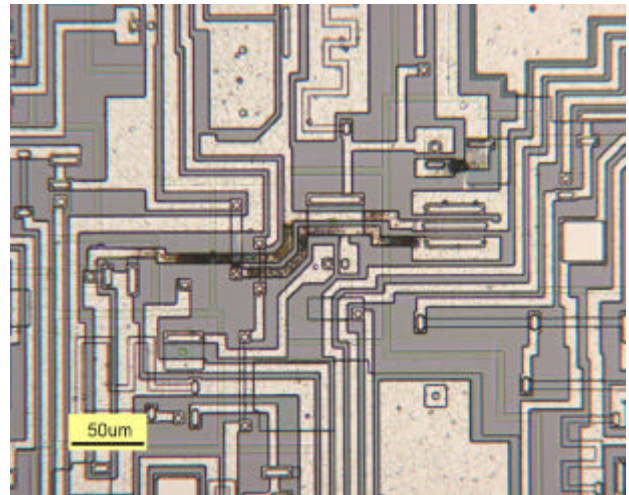

Figure 16. Note that damage was seen at multiple locations, a fact suggesting that failure was due to electrical overstress (EOS).

Appended Photographs:

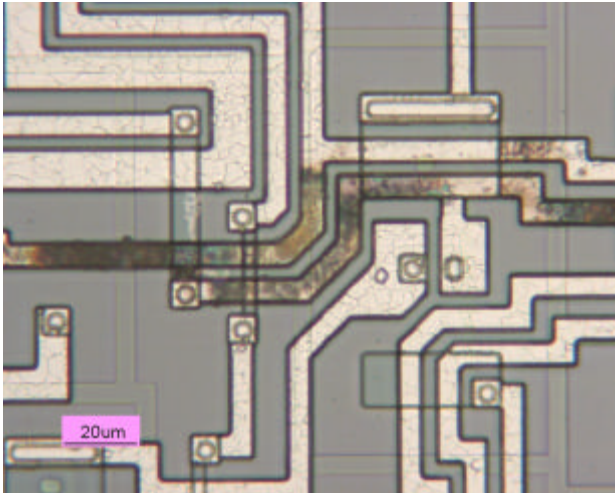

Figure 17. Another view of the thermal damage.

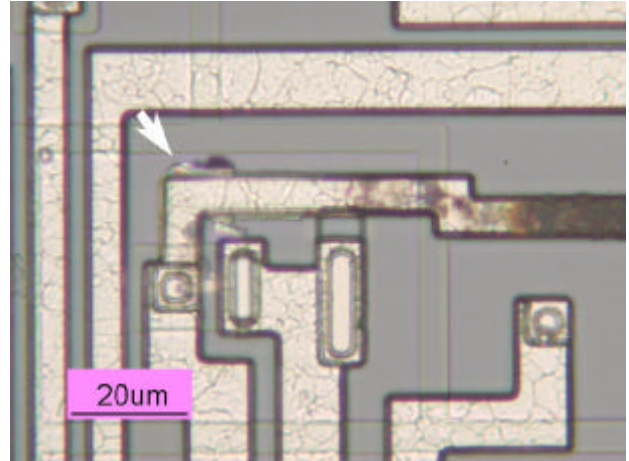

Figure 18. The arrow points to melted metalization found near a corner of an aluminum trace. Melted metal is also seen on the inside.

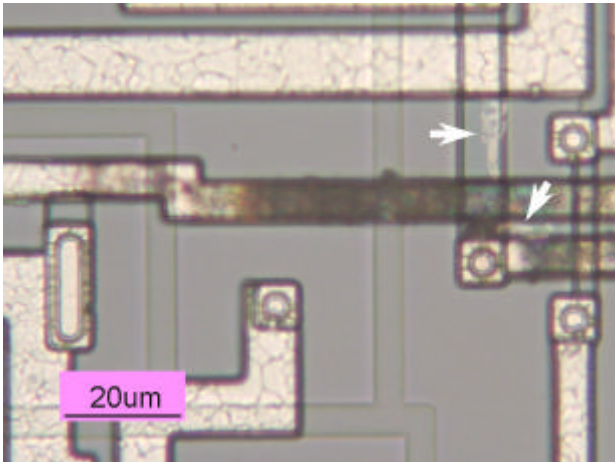

Figure 19. Only a strand of the original metal remains at the top arrow. The bottom arrow points to more evidence of melting.

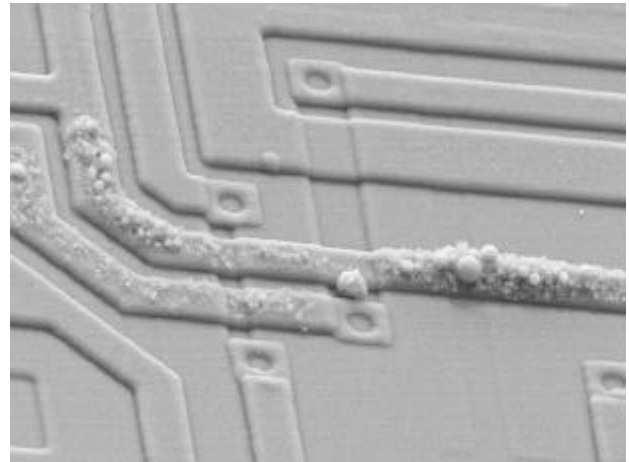

Figure 20. This SEM view, taken prior to sulfuric acid etching, shows baked-on plastic encapsulant, a phenomenon associated with heating of the traces.

GODDARD SPACE FLIGHT CENTER
Part Type Microcircuit
Manufacturer Linear Technology

Part Number LT1766IGN
Date Code 0150

Electrical Results:

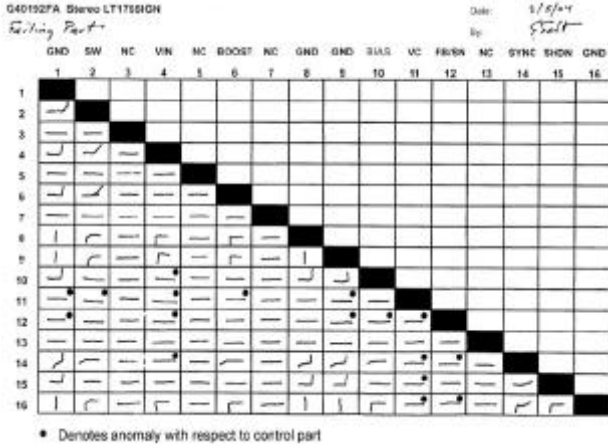

Figure 21. The microcircuit pin-to-pin curve tracer test results are shown above. Compared to a good part, anomalies were seen on pins 4, 11 and 12.

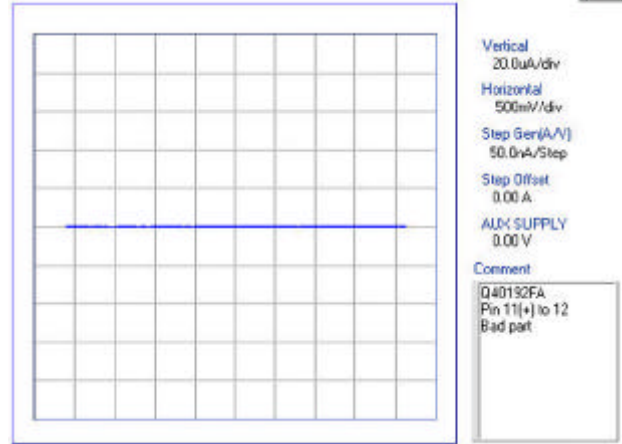

Figure 22. The curve tracer plot of Pin 11 (+) to Pin 12 on the failing part is shown above.

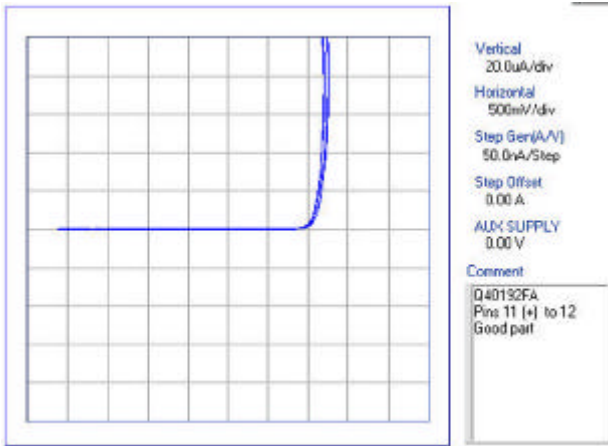

Figure 23. The curve tracer plot of Pin 11 (+) to Pin 12 on the control (good) part is shown above.

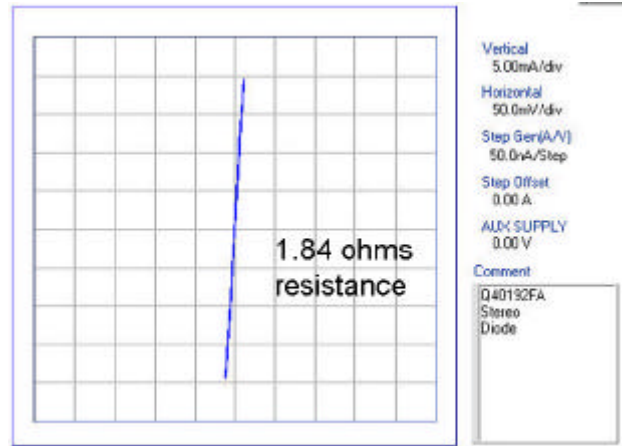

Figure 24. The curve tracer plot of the 1N4480 diode indicates that the diode was shorted with a 1.84 ohm resistance.

Electrical Results:

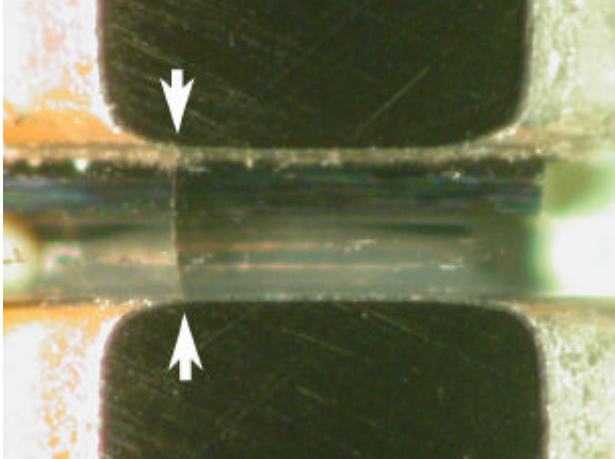

Figure 25. The white arrows bracket a crack in the diode glass, possibly caused by thermal stress.

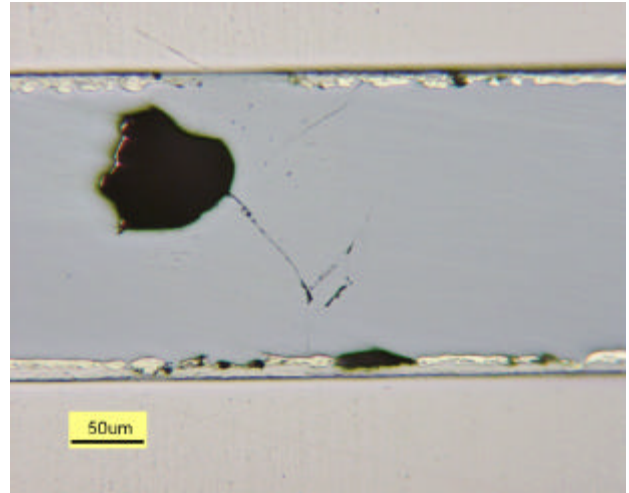

Figure 26. At cross-section Level 6 a large melt void and radiating cracks were found.

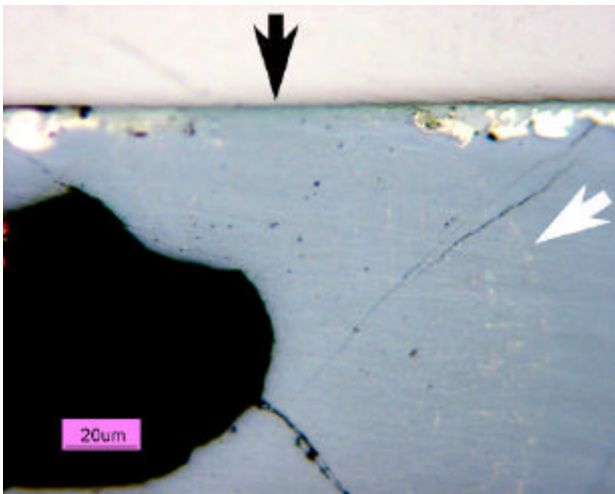

Figure 27. This image shows the void and cracks. The black arrow points to the middle of a missing section of metallurgical bond. The white arrow indicates a ring of dispersed metal which has re-alloyed due to heat.

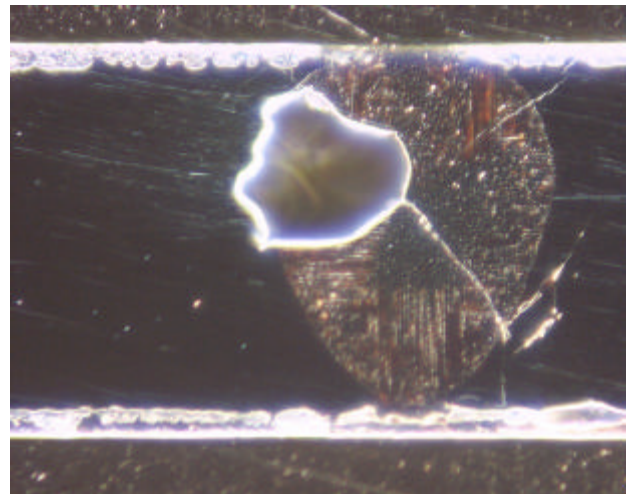

Figure 28. Dark-field examination of the damaged area found an egg-shaped region of re-alloyed material, pierced by cracks and interrupted on one side by the void—obvious evidence of heating. Note the symmetry of the re-alloyed, heated region, and the cracks radiating from the center. The anomaly spans between anode and cathode, creating a shorting path.